

AI-3500 Series Instruments

User Manual



1.Summary

Yudian touch screen instruments include:

- AI-3556/3556P/3559/3559P series artificial intelligence temperature controller/industry regulator,
- AI-35028/35048 multi-channel touch screen artificial intelligence temperature controller/industry regulator,
- AI-3502M/3504M/3506M multi-channel touch screen indicator.

2.Technical Specifications

2.1.Display

Color: TFT true color
Resolution (W × H): 800 × 480 pixels
Backlight: Long- lifespan LED
Operation method: Touch Screen

2.2.Memory

Usable memory for application data: 150 MB
Recording interval: interval with unit one second (1,2, 3 or 4 etc)

2.3.Communication

Interface type: RS232, RS485, Ethernet interface (10 / 100M adaptive Ethernet interface)
Baud rate: 1200-19200 bps

2.4.General Parameters

Electromagnetic compatibility (EMC) : ± 4KV/5KHz according to IEC61000-4-4;
4KV according to IEC61000-4-5.

Isolation withstanding voltage:

Between power, relay contact or signal terminals > 2300VDC;

between isolated Electroweak signal terminals > 600VDC

Power supply: 100~240VAC,-15%~+10%, 50-60Hz

Power consumption: < 5W

Operating ambience: Temperature: -10℃ ~ + 60℃ ; Humidity: < 90%RH

Storage temperature: -20℃ ~ + 80℃

Net weight: 0.55kg

Cooling: Natural

3.Instrument Installation

3.1.Hook Installation Diagram

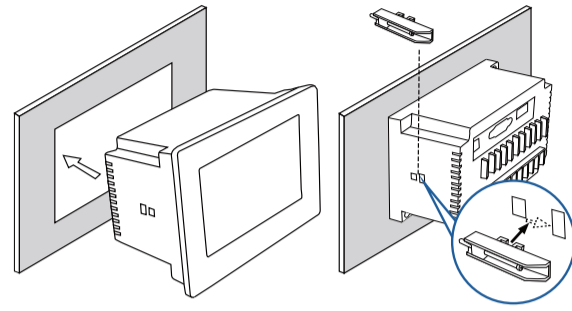

3.2.Dimensional Drawings

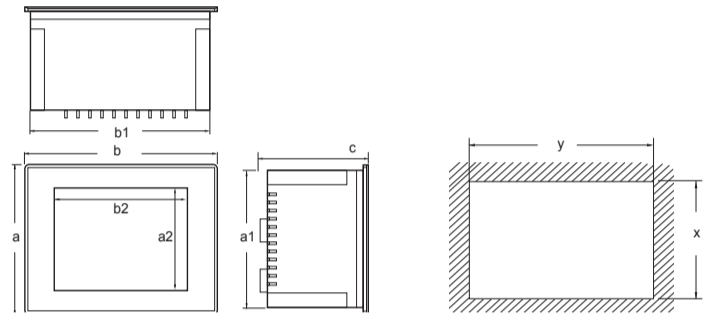

	Screen diagonal (mm)			Enclosure front (W × H × D) (mm)						Mounting Cutout (mm)	
	5inch	a2	b2	a	b	c	a1	b1	c1	x	y
3500 series	5inch	64	102	105	145	100	94	133	6	96	135

4.Instrument Wiring

4.1.Interface Type

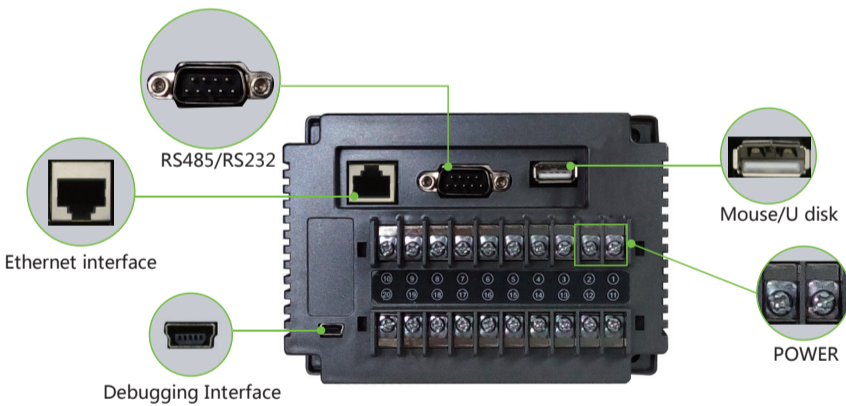

4.2.Power Wiring

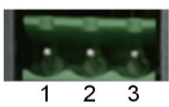

Interface	POWER		
PIN	1	2	3
PIN Definition	-	Blank	+

4.3.Communication Wiring

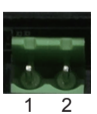

Interface	COM2(RS485)	
PIN	1	2
PIN Definition	RS485+	RS485-



Interface	COM2(RS485)		COM3(RS232)		
PIN	1	6	2	3	5
PIN Definition	RS485+	RS485-	RS232 RXD	RS232 TXD	RS232 GND

Note 1: For AI-3500 series, no communication wire is required if there is no expanded function module.

4.4.Input and Output Wiring

AI-3556/3556P/3559/3559P series artificial intelligence temperature controller/ industry regulator

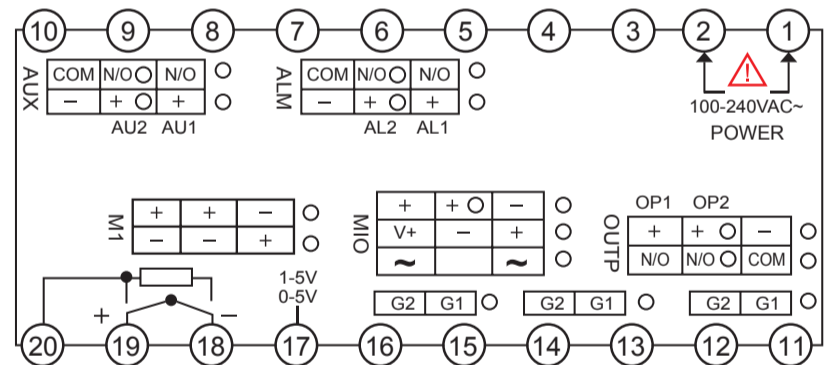

AI-35028/35048 multi-channel touch screen Artificial intelligence temperature controller/ industry regulator

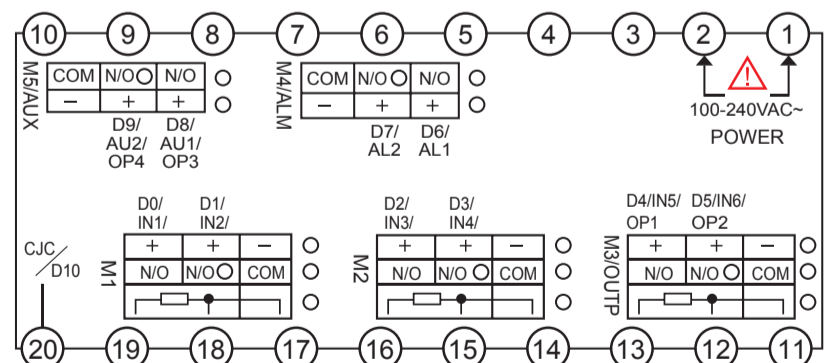

AI-3502M/3504M/3506M multi-channel touch screen indicator.

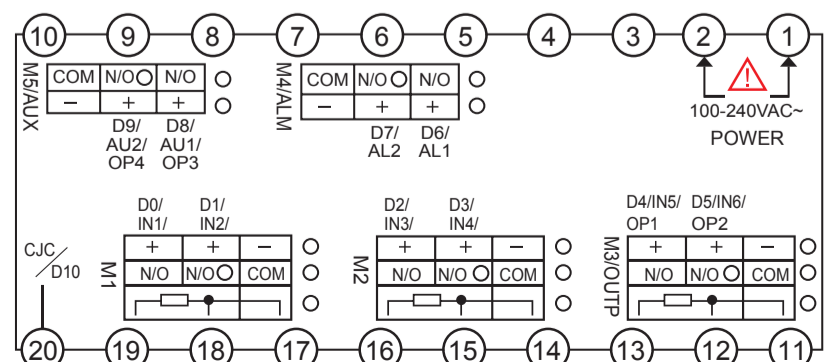

5.Operation Guidance

5.1 Instructions for First Time Operation:

When power is on, click **【MeterOpt】**, enter initial passcode 111.

At **【MeterOpt】** desktop:

- 1) Select the meter type corresponding to the channel name.
Note : AI-3500series get model type itself, just select the input type for AI-3502M/3504M/3506M
- 2) Click **【Reread】** **【Download】** to get default parameters or save new parameters.
Note 1: Select **【INP】**, **【DIP】** first, these two parameters are automatically saved when get modified, other parameters are affected when INP,DIP get modified.
Note 2: Once the other parameters are modified, the value will turn red unless **【Download】** button is clicked.
- 3) Click **【PrePage】** **【NextPage】** to view all parameters of current channel.
- 4) Click **【PreCH】** **【NextCH】** to switch channels. (every channel should follow above 1),2),3) steps if more than one channel.)
- 5) Click **【SetTime】** to reset current time. If the time is set backward, data recorded later will be erased, then the system will reboot itself.)

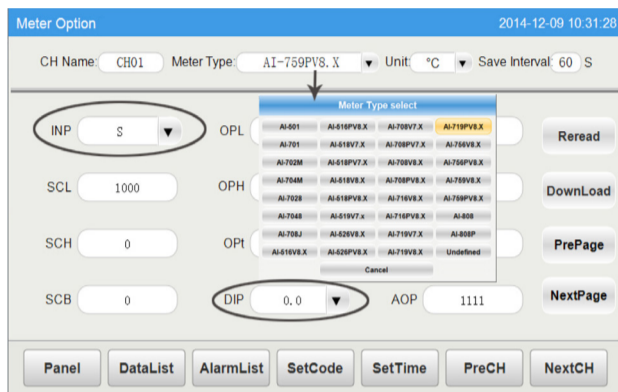

5.2 Instructions for Panel Desktop Operation:

- 1) Click **【Panel】**, parameters **【PV】**, **【SV】**, **【MV】** etc will show up.
- 2) When the alarm is ON, Channel name shows in red, click **【AlarmList】** to get more details.
- 3) Click **【Channel name】**, detailed informations of each meter, like PV, SV, MV, Running state, Manual/Auto state etc will show up. (Programmable meter shows further the Running time and Step time.)

-5-

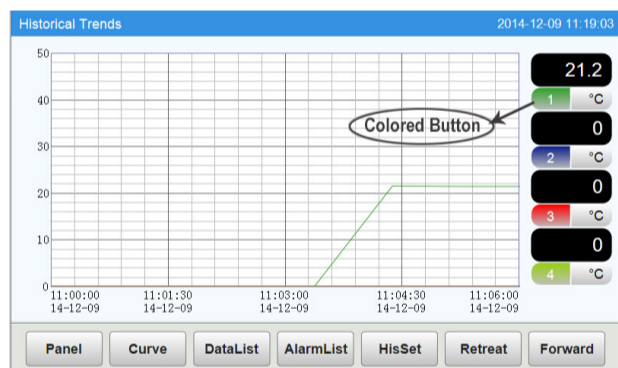

At **【RangeSet】** desktop:

Click **【RangeSet】** to set time span and Upper / Lower Range(range setting can be modified under manual state.)

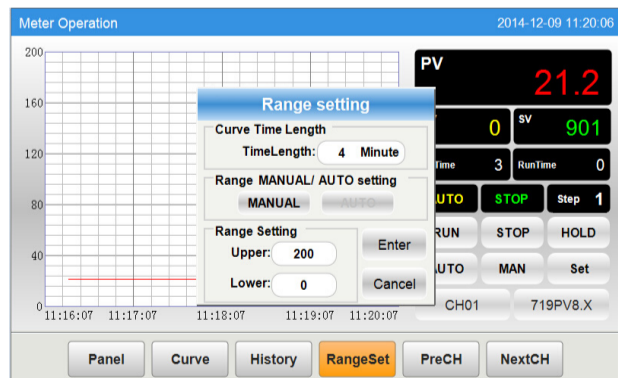

At **【DataList】** desktop:

- 1) Click **【Time】** to set start / end time.
- 2) Click **【Last 24H】** to view data of last 24 hours.
- 3) Click **【Current】** to view data from the start time to the current time.

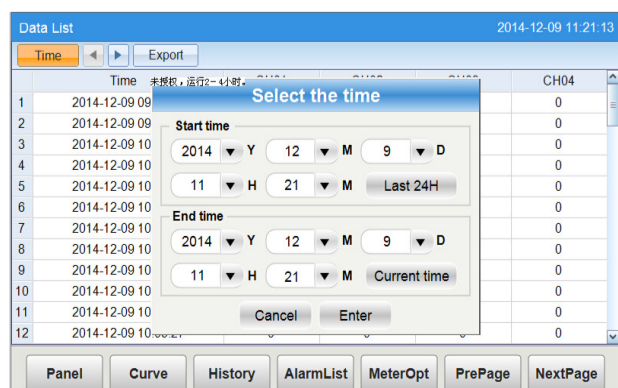

-7-

a.Curve graph shows **【PV】** in red while **【SV】** in green.

b.Click **【RUN】**, **【STOP】** to switch running state, entering initial passcode 111 for the first time.

5.3 Instructions for Field Parameter Setting:

- 1) Click **【Panel】**-**【Channel Name】**-**【Set】**, field parameters **【SV】** **【Step】** **【Scb】** **【AHYS】** **【HIAL】** **【LOAL】** **【MV】** will show up.
Note 1: **【MV】** can be set under Manual state.
Note 2: For programmable meters, click **【Program】** - **【Program Setting】** to set **【SV】**.
- 2) Click **【At ON】** **【At OFF】** to switch Auto-tuning state.
- 3) Click **【Program】** to go into program settings.
- 4) Click **【Reread】** **【Download】** to get default programs and save new programs.
- 5) Click **【Select】** to the formulation, you can modify, add ,delete, save or apply programs.
Note : Once programs are modified, the value will turn red unless **【Download】** button is clicked.

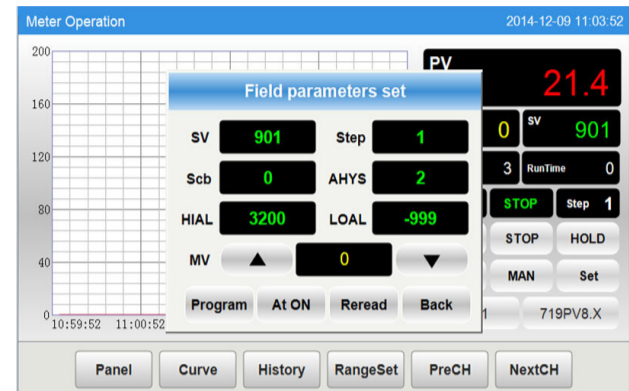

5.4 Instructions for Other Desktops Operation:

At **【Curve】** desktop:

- 1) Click colored button to show / hide real time curve.
- 2) Click **【CurveSet】** to set time and Upper / Lower range.

At **【History】** desktop:

- 1) Click colored button to show/hide history curve.
- 2) Click **【HisSet】** to set time and Upper/Lower range.
- 3) Click **【Retreat】** **【Forward】** to backward or forward 3/4 time axis.

-6-

DataList Export:

Insert USB disk and wait for a while for hardware recognition. Clicking **【Export】** will export the data tables in a file named "hisdata.csv" in the USB disk.

At **【AlarmList】** desktop:

- 1) Click **【Real】** **【His.】** to switch real(time) / history alarm list.
- 2) Click **【Options】** to select alarm type and display mode.

AlarmList Export:

Insert USB disk and wait for a while for hardware recognition. Clicking **【Export】** will export the data tables in a file named "almdata.csv" in the USB disk.

At **【MeterOpt】** desktop:

- 1) Select the meter type.
- 2) Select the unit.
- 3) Set record interval.(data recorded per 30S if you set "Save interval 30S" .)
- 4) Click **【SetPasscode】** to change initial passcode 111 to a new 3-digit one.
- 5) Click **【SetTime】** to set the current time.
If the time is set backward,, data recorded later will be erased, then the system will reboot itself.
- 6) Click **【Reread】** **【Download】** to get default parameters or save new parameters.
- 7) Click **【PreCH】** **【NextCH】** to switch channels.