



AI-8 Artificial Intelligence High-performance Multi-functional Industrial Regulator User's Manual (ver.9.1)



CONTENTS

1.SUMMARY	1
1.1 Main Features	1
1.2 Ordering Code Definition	3
1.2.1 AI-8 Panel-mounted/Rail-mounted Instrument.....	3
1.3 Using Modules	5
1.3.1 Function Definition of Module Socket.....	5
1.3.2 Models Common Module	5
1.3.3 Module Installation and Replacement.....	6
1.3.4 Electrical Isolation of Modules	6
1.3.5 Application Instruction for Certain Modules	7
1.4 Technical Specifications	8
1.5 Energy-saving and Environmental Protection Design	9
2. Installation and Wiring Method	10
2.1Installation	10
2.1.1Panel Mounting Method	10
2.1.2 Installation Method of DIN-rail Module	10
2.2 Wiring	10
2.2.1Precautions	10
2.2.2 Panel Mounted Instrument Wiring Diagram	11
2.2.3 DIN Rail Module Wiring Diagram	12
2.2.4Thermocouple Cold Junction Compensation Method Description	12
3.Display and Operation	13
3.1 Panel Description	14
3.2 Parameter Setting Process	15
3.3 Procedure Setting Process	15
3.4 Operating Instructions	16
3.4.1 Setting Parameters	16
3.4.2 Quick Operating Instructions	16
3.4.3 Instructions for E5 Rail Mounted Instruments	18
4.Parameter Description	19
4.1Typical Setting Process and Common Parameters	19
4.2 Parameter Lock and Custom Parameter Table	19
4.2.1 Parameter Lock(Loc).....	19
4.2.2 Custom Parameter Table.....	19
4.3 Complete Parameter Table	20
5. Common Function Description	35
5.1 SCR Trigger Output Function	35
5.1.1 Single-phase Phase-shift Trigger Output	35
5.1.2 Single-phase/Three-phase Zero-crossing Trigger Output	36
5.2.Position Proportional Output Function	36
5.2.1 Proportional output with feedback position	36
5.2.2 Proportional output with feedback position	37
5.3 External Event Input Function	37
5.4 Quick Tuning of AAT Function	37

5.5 External Given Function	38
5.6 Soft-starting Function	38
5.7 Heating and Cooling Dual output function	38
5.8 Overrange Output Definition Function	39
5.9 Limiting function of Temperature Rise/Fall Rate	39
5.10 Power-on Operation Mode Selection Function	40
5.11 Instrument Power Frequency and Temperature Unit Selection Function	40
5.12 Exempt from Alarm Function at Power-on	40
5.13 Communication Function	40
5.14 Temperature Transmitter/Programmed Generator	41
5.14.1 The OUPT terminal transmitting output	41
5.14.2 Transmit output at the COMM terminal (Note: only one of the functions of COMM position transmission, communication and event input can be selected)	42
5.15 Fine Control	42
5.16 Custom Input Specifications	42
5.17 Multi-segment Linear Correction Function of Input Signal	43
5.18 Nonlinear Power Control Function of High Temperature Furnace	44
6. Program Control (Pno≥1)	45
6.1 Function and Concept	45
6.2 Programming	46
6.2.1 Slope mode	46
6.2.2 Platform Mode	47
6.2.3 Set Program Given Value and Time	48
6.2.4 The Programming Method of Running Multiple Curves	48
7. Display/Alarm Symbols and FAQs	49
7.1 Display/Alarm Symbols	49
7.2 FAQs	50
7.2.1 How to self-tune?	50
7.2.2 How to enter the internal parameter table?	50
7.2.3 How to judge whether the instrument has output?	50
7.2.4 Instrument panel flashing orAL?	51
7.2.5 How to enter the program segment settings?	51
7.2.6 How to set alarm parameters?	51
7.2.7 How to set bidirectional output for heating and cooling?	51
7.2.8 How to set the external given function?	51
7.2.9 How to switch manual/auto output?	51

1.SUMMARY

1.1 Main Features

- The new AI artificial intelligence algorithm can accurately control even the large lag system, and is more adaptable to PID parameters.
- In addition to the classic AT self-tuning function, it has the AAT advanced and fast self-tuning function, which can analyze the heating curve to calculate the PID parameters when the equipment is powered on and heat up, and does not need to oscillate back and forth like the traditional AT, which greatly saves the equipment debugging time.
- The input can freely choose thermocouple, thermal resistance, voltage, current and expand the input and self-defined nonlinear correction table. The measurement accuracy of some input types can reach 0.05 level.
- High-precision low-temperature drift measurement technology is employed, which also uses 22/24BIT high-resolution A/D converter customized by Yudian as well as 50Hz/60Hz interference suppression function.
- Its power supply of the controller adopts the global switching power supply in the range of 100~240VAC, which provides comprehensive power protection function. Even if 380VAC is misconnected for a long time, it will not burn out; 24VDC power supply can also be selected, and it has a variety of external sizes to choose from.
- It attaches great importance to the design concept of energy saving and environmental protection, and selects "fever" grade energy-saving components. When there is no output and alarm, the power consumption of the whole machine is only about 0.2W, which greatly reduces the temperature rise of the instrument itself and improves product reliability and stability.
- It adopts advanced modular structure, provides rich output specifications, and can widely meet the needs of various application occasions, fast delivery and easy maintenance.
- It allows editing operation authority and field parameter table, and can set password to form "customized" instrument.
- Multiple communication protocols are supported, including the simple and efficient AIBUS protocol independently developed by Yudian and general MODBUS protocol, etc.; through the multi-functional communication controller, various network connection methods including TCP can be realized.
- Its strong anti-jamming design has passed the 6KV group pulse anti-jamming test, what's more, its anti-jamming performance meets the requirements of electromagnetic compatibility (EMC) under harsh industrial conditions.
- The digital tube is upgraded to a new generation of self-luminous LED display technology, with no light leakage or viewing angle problems, higher luminous efficiency, brighter colors, and greatly reduced power consumption, and different LED color matching modes can be selected.
- Instantaneous power failure protection function for grid undervoltage, the starting voltage is as low as about 50VAC, and the continuous working time is about 1 second after the power grid is instantaneously powered off.
- The designed temperature range is as wide as -10~+60 degrees, and high-precision crystal oscillator is used, and the actual aging test temperature is as high as 100 degrees.
- When the instrument has multiple sets of input and output, it can provide a complete solution of power supply and photoelectric isolation.
- When the parameter Pno is set to 0, the built-in program control function is fully compatible with the fixed-point operation mode. When it is set to 1, only the given value and timing control time need to be set. AI-8*8 series can support up to 50 programs control function.
- The automatic/manual non-disturbance switching function can be set to be used as a hand-held communicator.

- With external given value control function (only AI-8*8 series) and measured value / given value transmission as 4~20mA or 0~20mA output function.
- With built-in 50-point table/poly-line processing function, which can be used for multi-point correction of measured value input and high-temperature furnace output to follow the measured value limit and other functions.
- External event input function supports given value switching, PID parameter switching and manual/automatic non-disturbance switching.
- Besides the upper limit, lower limit, positive deviation, negative deviation and other alarm mode functions, its alarm output position can be set freely.
- A variety of thermocouple cold junction compensation modes can be selected: in addition to the common internal compensation mode, high-precision external CU50 and freezing point compensation modes are supported.
- When the sensor is disconnected, the output percentage can be defined, and the manual setting or the system autonomous limit can be selected.
- Various panel mounting and rail mounting options are available: including 48*48, 72*72, 48*96, 96*48, 96*96, 160*80, 80*160 and other panel mounting and D7 rail mounting modules.

 **CAUTION**

This manual introduces the AI-8 series artificial intelligence controller of version V9.2. Some of the functions introduced in thbetween different models and versions of the meter. Be sure to ask the user to read this manual carefully in order to use the instrument correctly and give full play to the function of this instrument. Before using the AI instrument, its input, output specifications and functional requirements should be correctly set to the parameters.is manual may not be suitable for instruments of other versions. The model and software version number of the instrument will be displayed on the display when it is powered on. Users should pay attention to the difference Only the instrument with the configured parameters can be put into use.

1.2 Ordering Code Definition

1.2.1 AI-8 Panel-mounted/Rail-mounted Instrument

The panel-mounted panel model of the AI-8 series artificial intelligence temperature controller/regulator consists of 9 parts:

AI-888 A N X3 L3 N S4 - 24VDC - F2
 ① ② ③ ④ ⑤ ⑥ ⑦ ⑧ ⑨

This means the instrument: ①the basic model is AI-888; ②the panel size is A type (96×96mm); ③the auxiliary input (MIO) has no module installed; ④the main output (OUTP) is installed with a linear current output module; ⑤Alarm ALM is installed with L3 dual relay contact output module; ⑥Auxiliary output (AUX) has no module installed; ⑦Communication interface (COMM) is equipped with photoelectric isolation RS485 communication interface S4 with its own isolated power supply; ⑧The power supply of the instrument is 24VDC power supply; ⑨The expansion input specification is F2 type (radiation type high temperature thermometer); the following are the meanings of the 9 parts in the instrument model:

① Indicates the basic model of the instrument

- AI-888 (level 0.1 accuracy, 10-year free warranty, full-featured artificial intelligence controller/regulator)
- AI-868 (level 0.15 accuracy, 8-year free warranty, full-featured artificial intelligence controller/regulator)
- AI-858 (level 0.2 accuracy, 5-year free warranty, full-featured artificial intelligence controller/regulator)
- AI-838 (level 0.25 accuracy, 3-year free warranty, full-featured artificial intelligence controller/regulator)
- AI-828 (level 0.3 accuracy, 2 years free warranty, full-featured artificial intelligence controller/regulator)
- AI-826 (level 0.3 accuracy, 2 years free warranty, multifunctional artificial intelligence controller/regulator)

Note: Compared with the 8*8 series, the 8*6 series lacks the valve forward/ reverse function and the external given function, and the program segment can be set to 1 segment at most.

② Indicates instrument panel size specifications

Socket Module	Welding Module	Panel Size
A	A1	Panel type, 96×96mm (W*H), hole size 92×92mm
A2	A21	Panel type, 96×96mm (W*H), with light bar
A5	A51	Panel type, 96×96mm (W*H), dual 5-digit display with light bar
A9	A91	Panel type, 96×96mm (W*H), double-row 5-digit display + third-row 4-digit display
B	B1	Panel type, 160×80mm (W*H), opening size 152×76mm
C	C1	Panel type, 80×160mm (W*H), opening size 76×152mm
D	--	Panel type, 72×72mm (W*H), hole size 68×68mm
--	D61	Panel type, 48×48mm (W*H), opening size 45 ^{+0.5} ×45 ^{+0.5} mm
D7	D71	DIN rail type, built-in display, pluggable terminals, installation width 22.5mm
E	E1	Panel type, 48×96mm (W*H), hole size 45×92mm
E2	E21	Panel type, 48×96mm (W*H), with light bar
E3	E31	Panel type, 48×96mm (W*H), three rows of 4-digit display
E9	E91	Panel type, 48×96mm (W*H), double-row 5-digit display + third-row 4-digit display
E5	E51	DIN rail type, width 48mm, no display window by itself, external E85 display
F	F1	Panel type, 96×48mm (W*H), hole size 92×45mm

③ Indicates the module specifications installed by the instrument auxiliary input (MIO): I2、I5、I44、K3、Vand other modules can be installed, N means not installed, the same below.

- ④ **Indicates the module specifications installed on the main output (OUP) of the instrument:** L1, L2, L4, L5, W1, W2, G, K1, K3, X3, X5 and other modules can be installed. 8*6 series do not support OUP to install L5 module to realize the valve forward and reverse.
- ⑤ **Indicates the module specifications installed by the instrument alarm (ALM):** L2, L21, L3, L4, W1, W2, G and other modules can be installed.
- ⑥ **Indicates the module specifications of the instrument auxiliary output (AUX) installation:** L1, L2, L21, L3, L4, W1, W2, G, K1, X3, X5 and other modules can be installed.
- ⑦ **Indicates the module specifications installed by the instrument communication (COMM):** S, S4, V and other modules can be installed.
- ⑧ **Indicates the power supply of the instrument:** if not written, it means using 100~240VAC power supply, 24VDC means using 20-32VDC power supply.
- ⑨ **Indicates the extended scale specification of the instrument** (if not, do not write it), AI-8 series has stored the commonly used thermocouple and thermal resistance input specifications (see the technical specifications later for details), but if the specifications other than the above are used Input signal, users are allowed to expand an input specification.

Note 1: This instrument is a maintenance-free instrument that adopts automatic zero adjustment and digital calibration technology. If the measurement is out of tolerance, the problem can be solved by cleaning and drying the inside of the instrument. If drying and cleaning cannot restore the accuracy, this instrument is regarded as a faulty instrument and sent back to the factory for maintenance;

Note 2: The instrument provides free warranty during the warranty period. For any instrument that needs to be repaired, be sure to write down the fault phenomenon and reason and contact information to ensure that the correct and comprehensive repair can be obtained.

1.3 Using Modules

1.3.1 Function Definition of Module Socket

AI-8*8 series instruments have 5 (MIO\OUTP\ALMAUX\COMM) optional function module sockets (including 3 for D, D61 panel type and D7 rail type, namely OUTP, AUX and COMM /AL1; D71 rail type can be installed with 4 modules of OUTP, AUX, ALM and COMM); by installing different modules, different types of output specifications and functional requirements can be achieved.

Modular Socket		Function Description	Optional Modules
Auxiliary Input	MIO	Functions as extended input or event input or feed output or extended output	I44\I2\I24\I12 etc.
Main Output	OUTP	Functions as ON-OFF output or PID adjustment output or transmission output	L1\L5\G\X3\K1\K50\K3 etc.
Alarm	ALM	Functions as upper and lower limit/deviation alarm output or power feed output	L21\L3\I10\I24 etc.
Auxiliary Output	AUX	Functions as the second output of heating and cooling or alarm output or RS232 communication	L1\L21\L3\G\X3\K1\R etc.
Communication Interface	COMM	Functions as RS485 communication or transmission output or event input	S\S1\S4\X3\X5\I2 etc.

1.3.2 Models Common Module

Name	Function Description
N (or /)	No module installed
L1	Large-capacity large-volume relay normally open contact switch output module, module capacity: 30VDC/2A, 250VAC/2A.
L2	Small capacity small volume relay normally open + normally closed contact switch output module, module capacity: 30VDC/1A, 250VAC/1A, suitable for alarming.
L21	Small capacity small volume relay normally open + normally closed contact switch output module, module capacity: 30VDC/1A, 250VAC/1A, suitable for alarming.
L3	Two-way large-capacity large-volume relay normally open contact switch output module, capacity: 30VDC/2A, 250VAC/2A.
L4	Large capacity small volume relay normally open + normally closed contact switch output module, module capacity: 30VDC/2A, 250VAC/2A.
L5	Two-way large-capacity large-volume relay normally open contact switch output module, capacity: 30VDC/2A, 250VAC/2A.
W 1、W 2	SCR non-contact output module, W1 is normally open type, W2 is normally closed type, capacity: 100~240VAC/0.2A, "not burn out" feature, no welding type module
W5	Two-way SCR non-contact and 5V voltage output module, dedicated for valve motor control, capacity: 100~240VAC/0.2A, "not burn out" feature, no welding module
G	Solid state relay driving voltage output module, 12VDC /30mA.

G5	Two-way solid state relay drive voltage output module, two-way 12VDC /30mA.
K50/K60	One-way 220VAC/380VAC "not-burn-out" one-way SCR phase-shift trigger output module.
K1/K3	One-way/ three-way "not-burn-out" SCR zero-crossing trigger output module, each can trigger 5~500A bidirectional or two anti-parallel one-way SCR. K3 Solderless Modules.
X3	Photoelectrically isolated programmable linear current output module.
X5	Photoelectrically isolated programmable linear current output module with its own isolated power supply.
S	Photoelectrically isolated RS485 communication interface module (use the internal 24V isolated power supply of the instrument).
S1	Photoelectrically isolated RS485 communication interface module (use the internal 24V isolated power supply of the instrument).
S2	Photoelectrically isolated RS485 communication interface module
S4	Photoelectrically isolated RS485 communication interface module with its own isolated power supply.
R	Photoelectrically isolated RS232C communication/printing interface module (if printing function is required, please specify).
V24 / V12 / V10 / U5	Isolated 24V/12V/10V/5V DC voltage output, available for external transmitters or other circuits, with a maximum current of 50mA.
I2/I5	Switch/frequency signal input interface, which can be used for external switch contact or frequency signal input.
I44	Analog 4~20mA/0~20mA input interface, including 24VDC/25mA power output for the use of two-wire transmitter.

Note: please check the selection manual or call technical support for other modules not listed.

1.3.3 Module Installation and Replacement

The module can be installed before the instrument is delivered, and the corresponding parameters can be set correctly according to the user's requirements when ordering. If the module is damaged or the function needs to be changed, the user can also replace the module by himself. When replacing the module, you can pull out the instrument movement, use a small flat-blade screwdriver to carefully pry open the seam between the original module and the socket on the motherboard, remove the original module, and then install the new module according to the label. If the module type is changed, it is also necessary to change the setting of the corresponding parameters.

The welded module is solidified on the internal circuit board of the instrument. Please confirm the functional requirements before ordering to avoid wrong module selection.

1.3.4 Electrical Isolation of Modules

There are 1 group of 24V and 1 group of 12V power supply isolated from the main line inside the instrument for module use, 24V power supply is usually used for voltage output modules, such as V24/V12/V10 (24V/12V/10V voltage output), I2 (frequency / switch input, its 12V output voltage can be isolated) or modules such as I4. The 12V power supply is used for the output and communication modules; the relay and SCR trigger output modules usually have their own isolation or do not need to use an isolated power supply, so the isolation between the communication interface and

the current output is mainly considered, S (RS485 communication interface), R (RS232 communication interface)), X3 (linear current output), the input and output terminals of which are electrically isolated from the input circuit of the instrument, that is, the main line, but these modules all need to use the 12V isolation power supply provided by the instrument. If the user installs the above two modules with isolation function at the same time, the two modules cannot be electrically isolated from each other because they share the power supply of the isolated part. For this purpose, new modules such as S4 (RS485 communication interface) and X5 (linear current output) are designed. These modules have their own high-efficiency DC/DC power isolation converters and do not occupy the internal isolation power of the instrument. For example: X3 module is installed at the main output (OUP) position of the instrument, if S or X3 module is installed on the communication interface (COMM), the X3 and S or X3 modules cannot be isolated, and the S4 or X5 module should be installed. For relay contact output and SCR non-contact switch output, they are isolated from other circuits and are not limited by whether other modules are installed; and SSR voltage output module (G module) generally does not need to add additional isolation, because The usual SSRs have isolation capabilities themselves.

1.3.5 Application Instruction for Certain Modules

Voltage Output Modules: power output modules such as V24, V10 and V12 usually provide power for external sensors and transmitter feedback resistors. This module can be installed on any module socket, but in order to make the wiring specification, it is recommended to orderly install the modules in the positions of MIO, AUX and COMM according to whether the module positions are free.

Non-contact Switch Module: W1/W2 is a new type of non-contact switch module designed by applying advanced "not-burn-out" protection technology and zero-crossing technology. It can replace the relay contact switch output commonly used in the past to control the AC contactor or the servo motor of the electric actuator. Compared with the relay contact output module, it has the advantages of long life and can greatly reduce the interference spark of the equipment. In addition, it can greatly improve the reliability of the system. The driving element of the non-contact switch is SCR, thus it is only suitable for controlling the AC power supply of 100-240VAC specification, and cannot be used to control the DC power supply. Since the output terminal is connected in series with a protection device, the maximum continuous control current is 0.2A, and the instantaneous current is allowed to reach 2A. This driving capacity can directly control the AC contactor below 220AC and 80A, but for larger loads, it is necessary to add an intermediate relay. W5 is a 2-way non-contact switch specially designed for position proportional output, with a driving capacity of 1A, which can directly drive a servo motor with a voltage below 200W and a voltage of 220VAC. At the same time, W5 also has a 5V voltage output, which can be used to connect 1K valves feedback resistor.

Relay Module: The relay module is a very widely used output module in industrial control, but it is also the only module with service life problems and height restrictions among various modules. In addition, the action of the relay often brings a lot of electromagnetic interference, so it is important to correctly choose the relay modules. W1 module is recommended to use to control the output of mechanical switches such as contractors and solenoid valves powered by 220VAC, yet to control DC or AC power below 50VAC, only relay modules can be used, and modules such as L1 and L4 can be used. The L2 type module is a small volume module without volume limitation, and has normally open + normally closed contacts and has the function of varistor spark absorption, while the contact capacity is small, which is suitable for alarm output. L1 and L3 are large-volume and large-capacity relay modules. In the instrument with a width of 48mm (including E, F, E5 and other sizes), this kind of modules cannot be installed on the main board or side plate at the same time, otherwise they will meet together. Therefore, when the L1 or L3 is installed on one side, the output module should be installed on the other side instead of the L1 or L3 module again. L3 is the only two-way relay module, which can be used for 2-way alarm output, such as AL1+AL2, etc. External solid state relays (SSRs) such as G5 (SSR voltage) can also be used to drive the load if mechanical contacts are not preferred or cannot be installed due to height constraints.

1.4 Technical Specifications

● Input specifications (one instrument can be compatible):

Thermocouple: K, S, R, E, J, T, B, N, WRe3-WRe25, WRe5-WRe26, etc.

Thermal resistance: Cu50, Pt100, Ni120

Linear voltage: 0~5V, 1~5V, 0~1V, 0~100mV, 0~20mV, -5~+5V, -20mV~+20mV, etc.

Linear current (requires external shunt resistor or install I44 module): 0~10mA, 0~20mA, 4~20mA, etc.

Extended Specifications: On the basis of retaining the above input specifications, users are allowed to customize an additional input specification

● **Measurement range:** K(-50~+1300°C), S(-50~+1700°C), R(-50~+1700°C), T(-200~+350°C), E(0~800°C), J(0~1000°C), B(200~1800°C), N(0~1300°C), WRe3-WRe25(0~2300°C), WRe5-WRe26(0~2300°C), Cu50(-50 ~+150°C), Pt100(-200~+800°C), Pt100(-80.00~+300.00°C)

Linear input: -9990~+32000 defined by user

● **Measurement accuracy:** level 0.05~0.1/0.1/0.15/0.2/0.25/0.3 (Note: When higher accuracy is required for thermocouple input, an external PT100 thermal resistor should be connected for compensation, and an additional compensation error of $\pm 1^\circ\text{C}$ will be added during internal compensatio; Class 0.05 refers to some input specifications of AI-898, including PT100, S and B thermocouple, and mV input supporting class 0.05 measurement accuracy)

● **Measurement temperature drift:** $\leq 25\text{PPm}/^\circ\text{C}$ (level 0.05~0.1); $\leq 50\text{PPm}/^\circ\text{C}$ (level 0.1~0.15); $\leq 100\text{PPm}/^\circ\text{C}$ (level 0.2~0.3)

● **Control cycle:** adjustable from 0.1 to 300.0 seconds

● Adjustment method:

Position adjustment method (adjustable hysteresis)

AI artificial intelligence adjustment, advanced control algorithm including fuzzy logic PID adjustment and parameter self-tuning function

Standard PID tuning

● Output specifications (modular):

Relay contact switch output (normally open + normally closed): 250VAC/2A or 30VDC/2A

SCR non-contact switch output (normally open or normally closed): 100~240VAC/0.2A (continuous); 2A (20mS momentary, 5S repetition period)

SSR voltage output: 12VDC/30mA (for driving SSR solid state relay)

SCR trigger output: can trigger 5~500A bidirectional SCR, 2 unidirectional SCR anti-parallel connection or SCR power module

Linear current output: 0~10mA or 4~20mA can be defined (maximum output voltage of energy-saving modules $\geq 5.5\text{V}$; high-voltage output voltage $\geq 10.5\text{V}$)

● **Alarm function:** There are 4 modes, such as upper limit, lower limit, upper limit deviation, lower limit deviation, etc., which can output up to 4 channels, and has the function of power-on exemption alarm selection

● **Electromagnetic compatibility:** IEC61000-4-4 (electrical fast transient burst) $\pm 6\text{KV}/5\text{KHz}$, IEC61000-4-5 (surge) 6KV, and under the interference of 10V/m high-frequency electromagnetic field, the instrument does not crash, the I/O malfunctions will not emerge either, and the fluctuation of the measured value does not exceed $\pm 5\%$ of the range.

● **Isolation withstand voltage:** the voltage between power supply terminals, relay contacts and signal terminals is $\geq 2300\text{V}$, while the voltage between the isolated weak current signal terminals is $\geq 600\text{V}$.

● **Power supply:** 100~240VAC or DC, -15%, +10% / 50~60Hz; or 24VDC/AC, -15%, +10%

● **Power consumption:** $\leq 0.3\text{W}$ (including CPU, measurement, display and communication, excluding any output or external power consumption)

● **Using environment:** temperature -10~60°C; humidity $\leq 90\%\text{RH}$

1.5 Energy-saving and Environmental Protection Design

The AI-8 series adopts an energy-saving and environmentally friendly design, which is reflected in its extremely low temperature drift and its own extremely low power consumption. In order to achieve this, high-quality components are used, and low-temperature drift products are selected for key components and have been tested in pairs. Low temperature drift values can achieve better energy-saving effects in various applications. Yudian even pays attention to the power consumption of the instrument itself. For example, the use of LED displays with higher luminous efficiency can effectively reduce the driving current under the same brightness, reduce its own power consumption, and improve the reliability and performance of the product itself.

Compared with ordinary temperature control instruments, the low temperature drift instrument has less change in the measured value of temperature due to the influence of ambient temperature. which can not only make the customer's product quality more stable, but also effectively reduce energy consumption. This turns out to make the high-precision instruments more energy-efficient than the instruments with lower precision due to their low temperature drift, for example, assuming that the sintering temperature range of a ceramic material is around 1000~1010°C, and assuming that the temperature drift of an ordinary instrument on the market is about $\pm 5^{\circ}\text{C}$ (caused by the change of ambient temperature in winter, summer and morning and evening), therefore, it is necessary to set the instrument at 1005°C (the temperature range is 1000~1010°C) to maintain normal production under different ambient temperature changes. While the temperature drift of AI-8 series instruments can be reduced to within $\pm 0.3\sim 1^{\circ}\text{C}$. In this case, setting the temperature at 1001°C (temperature range of 1000~1002°C) can stabilize production, so that the average temperature of the kiln can be reduced by 3 ~4°C, and the lower the average temperature of an industrial furnace, the less power it consumes. In most application scenarios, 0.3%~1% energy can be saved by reducing the temperature drift of the instrument and optimizing the debugging, and the product quality can be more stable.

2. Installation and Wiring Method

2.1 Installation

2.1.1 Panel Mounting Method

① The distance between the installation holes of the instrument should be set at an appropriate distance according to different sizes and installation brackets. If necessary, the instruments can be installed side by side closely. It is recommended that the left and right spacing of A/D/D61/C/E size is $\geq 8\text{mm}$, and the upper and lower spacing is $\geq 30\text{mm}$; the left and right spacing of B/F size is $\geq 30\text{mm}$, and the upper and lower spacing is $\geq 8\text{mm}$.

② Insert the instrument into the panel mounting hole, press the mounting bracket from the opening side of the case, and temporarily fix the main body.

③ When tightening the mounting bracket and terminal wiring, please set the tightening torque to $0.39\sim 0.58\text{N}\cdot\text{m}$.

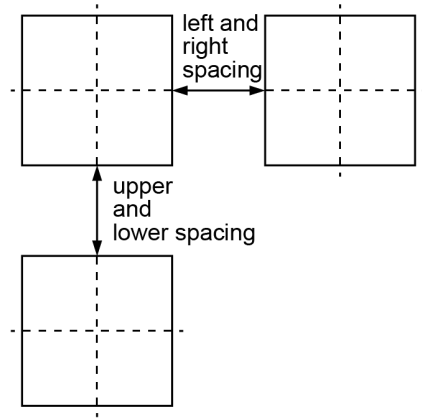

2.1.2 Installation Method of DIN-rail Module

① Install the module on the 35mm DIN rail.

② The rail module must be installed vertically, and the recommended distance is at least 50mm.

③ When wiring the terminals, please set the tightening torque to $0.39 \sim 0.58\text{N}\cdot\text{m}$.

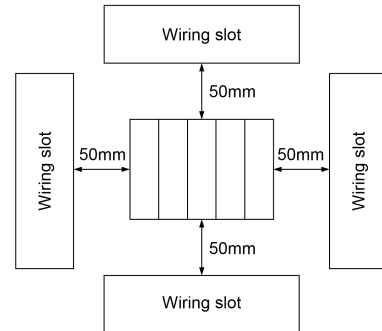

2.2 Wiring

2.2.1 Precautions

① In order to avoid interference, please separate the signal line and the power supply line.

② Please use shielded wire (cross-sectional area $0.5\text{mm}^2 \sim 1.25\text{mm}^2$) for the cable, and ground the shielding layer at one end. The stripping length of the wire should be $6 \sim 8\text{mm}$.

③ Please use crimp terminals for terminal wiring, and use wiring materials and crimp tools suitable for crimp terminals. For crimp terminals, use M3.0 terminals.

2.2.2 Panel Mounted Instrument Wiring Diagram

Note: Due to technical upgrades or special orders, etc., if the random wiring diagram of the instrument is inconsistent with this manual, please refer to the random wiring diagram. The E5/E51 rail wiring is the same as the panel mounted instrument.

■ The terminal arrangement of the rear cover of the instrument is as shown in the figure:

① The linear voltage range below 100mV is input from 19+ and 18- terminals, and the voltage signal of 0~1V and above is input from 17+ and 18- terminals;

② The 4~20mA linear current input can be converted into a 1~5V voltage signal with 250 ohms, and then input from the 17+ and 18- terminals. The I44 module can also be installed at the MIO position to input from the 14+ and 15-terminals, or directly connect to the two-wire transmitter from the 16+ and 14- terminals;

③ Thermocouples with different graduation numbers use different compensation wires for thermocouples. When using the internal automatic compensation mode, the compensation wires should be directly connected to the terminals on the back cover of the instrument, and cannot be converted into ordinary wires in the middle, otherwise measurement errors will occur.

④ When the main output is current and SSR voltage output, it is output from terminals 13+ and 11-.

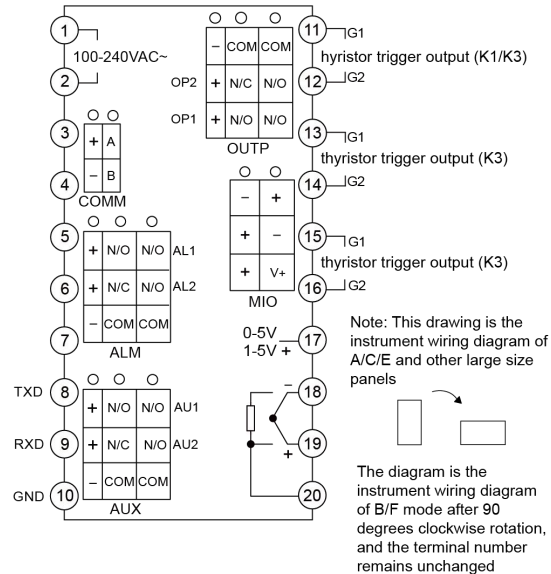

■ The wiring diagram of D-type panel instrument (72mmX72mm) is as follows:

Note 1: The linear voltage range of 0~100mV and below is input from the 13+ and 12- terminals, and the voltage signal of 0~1V and above is input from the 11+ and 12- terminals.

Note 2: 4~20mA linear current input can be changed into 1~5V voltage signal with 250Ω resistance, and then input from 11+ and 12- terminals.

Note 3: The COMM position is used for communication when the S or S4 communication interface module is installed; when the relay/contactless switch/SSR voltage output module is installed, it is used for AL1 alarm output; when the I2 module is installed and the bAud parameter is set to 1, the digital input function of the MIO module can be virtualized, and the external switches at terminals 3 and 4 can realize SP1/SP2 switching or be used to control the operation/stop of the program and other functions.

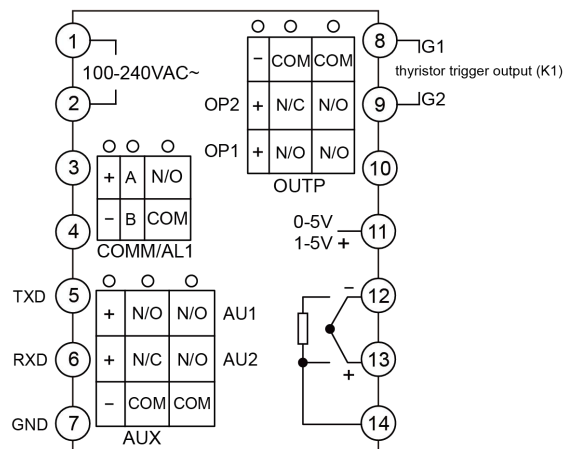

■ The wiring diagram of E7 panel instrument (22.5X100mm) is as follows:

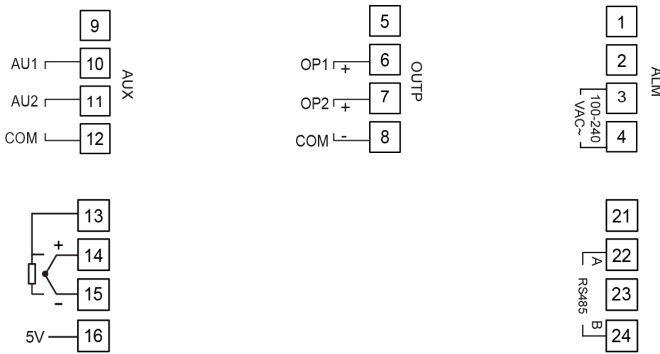

Note 1: 0~5V/1~5V and above voltage signals are input from 16+, 15-, 0~100mV and below signals are input from 14+, 15-; 4- 20mA linear current input and 250 ohm resistor into 1-5V, then input from 16+, 15-.

2.2.4 Thermocouple Cold Junction Compensation Method Description

Using the wiring method to select the thermocouple cold junction automatic compensation mode: When a thermocouple is used as the input signal, according to the principle of thermocouple temperature measurement, it is necessary to perform temperature compensation on the cold end of the thermocouple. The AI instrument can measure the temperature near the rear terminal of the meter and automatically compensate the cold end of the thermocouple. However, due to the error of the measuring element, the heating of the instrument itself and other heat sources near the instrument, etc., the automatic compensation method often results in a large deviation, which may exceed 2°C in the worst case. Therefore, when the temperature measurement accuracy is required to be high, an external junction box can be installed, and the PT100 resistor (to be purchased separately) and the cold end of the thermocouple are placed together and kept away from various heating objects, so that the measurement inconsistency due to compensation can thus be less than 0.3°C. because of the error of the Cu50 copper resistor itself, there may be a little error at room temperature, which can be corrected by the Sc parameter. By changing the external copper resistance into a precision fixed resistance, the compensation function of the constant temperature bath can also be realized. For example, an external 60 ohm fixed resistor can be used to check the Cu50 indexing table to obtain a compensation temperature of 46.6°C. At this time, the cold end of the thermocouple can also be accurately compensated by placing it in a constant temperature bath with a control temperature of 46.6°C, and its compensation accuracy is better than that of copper resistors. If the external resistor is changed into a short-circuit line, the freezing point compensation can be achieved. At this time, it is required to place the cold end of the thermocouple (the connection between the thermocouple or the compensation wire and the ordinary wire) in the ice-water mixture (0°C), and the compensation accuracy can be as high as 0.1°C or more. The wiring diagrams of the two compensation modes are as follows:

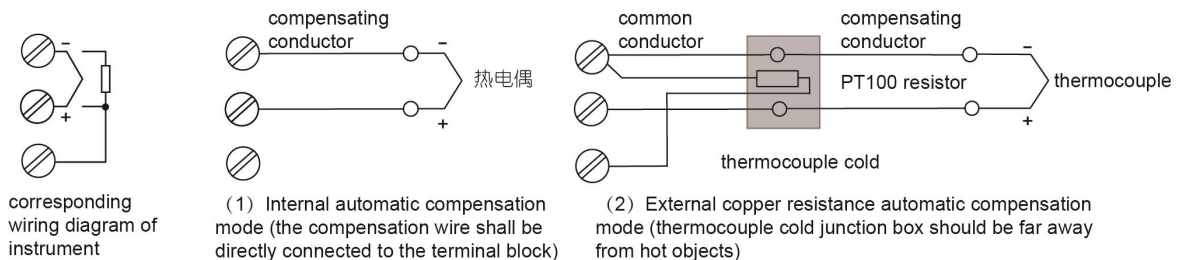

3.Display and Operation

3.1 Panel Description

- ①The upper display window displays the measured value PV, parameter name, etc.
- ② The middle display window displays the given value SV, alarm code, parameter value, etc.
- ③The lower display window displays the output percentage MV
- ④Setting key, used to enter parameter setting state, confirm parameter modification, etc.
- ⑤ Data shift (also fixed-point control operation)
- ⑥ Data reduction key (also run/pause operation)
- ⑦ Data increase key (also stop operation)

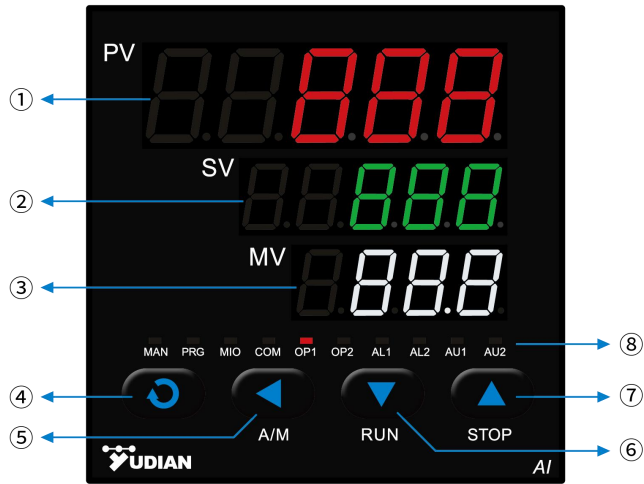

⑧10 LED indicator lights, MAN light on means in manual output state; PRG light on means in program running state, flashing in wait function state; The MIO, OP1, OP2, AL1, AL2, AU1, AU2 lights correspond to the input and output actions of the corresponding position module respectively; the COM light flashes to indicate that it is communicating with the upper computer.

Panel Description

- ① The upper display window displays the measured value,PV, parameter title, etc .
- ② The middle display window displays the set value SV, alarm code, parameter value, etc .
- ③ Setting key is used to enter parameter setting state and confirm parameter modification.
- ④ Data shift (also fixed-point control operation)
- ⑤ Data reduction key (also run/pause operation)
- ⑥ Data increase key (also stop operation)
- ⑦ Data increase key (also switch to display the next channel)
- ⑧9 LED indicators, among which M and A correspond to Models with manual automatic and MIO input functions. O1, O2, O3, O4, O5, and O6 correspond to OP1, OP2, AU1, AU2, AL1, and AL2 respectively; The C light flashes to indicate that it is in communication.

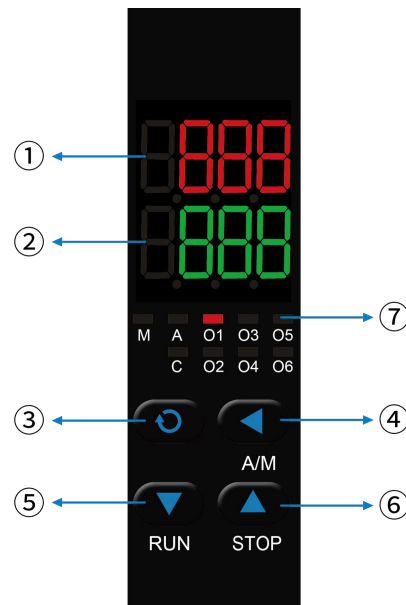

3.2 Parameter Setting Process

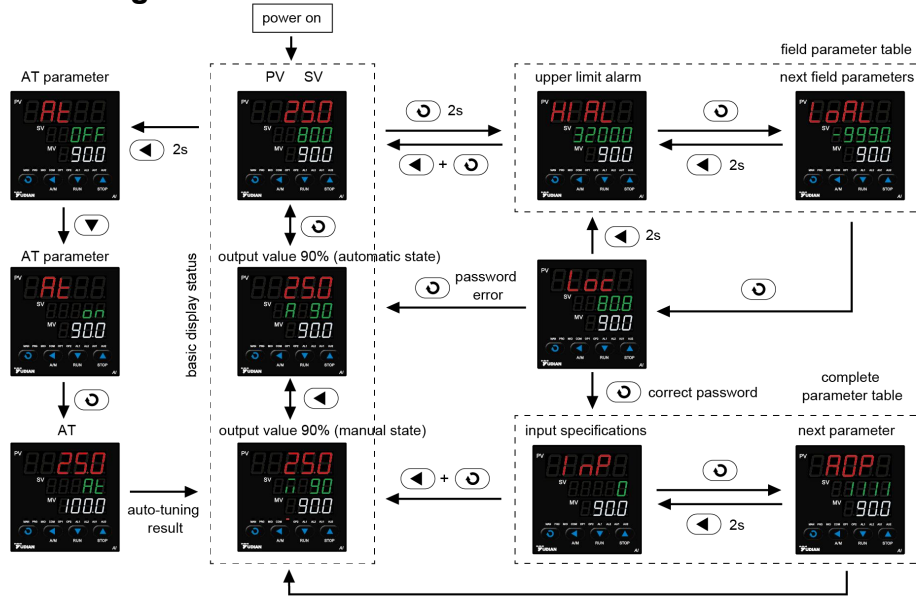



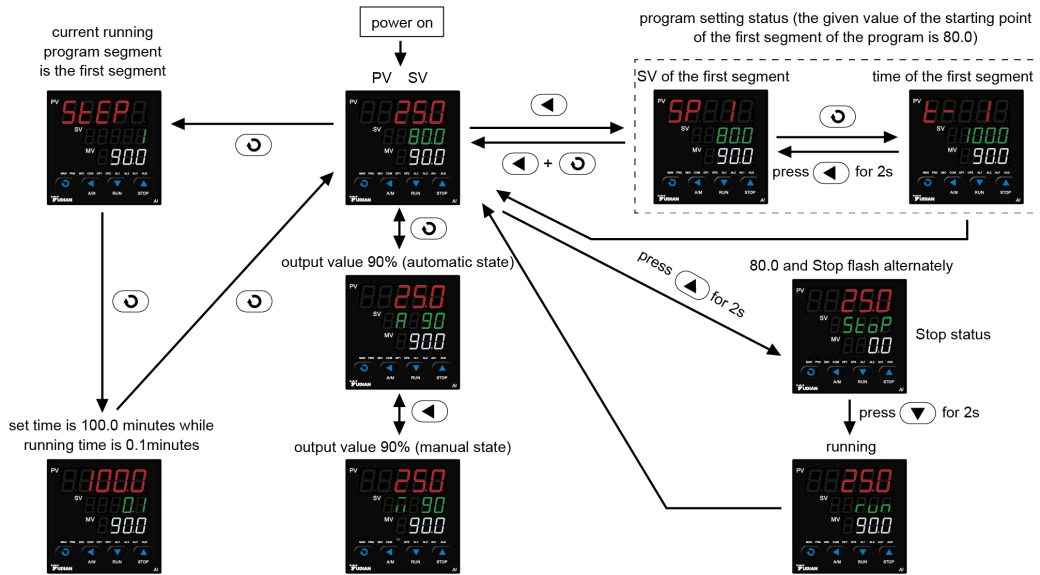









3.3 Procedure Setting Process







3.4 Operating Instructions



3.4.1 Setting Parameters

Press and hold the key  for about 2 seconds in the basic display state to enter the customized on-site parameter setting state. Directly press , ,  and other keys to modify the parameter value. Press the key  to decrease the data, press the key  to increase the data, the decimal point of the modified numerical digit will flash (like a cursor). Press and hold the key to quickly increase/decrease the value, and the speed will automatically increase as the decimal point moves to the right. Or press the key  to directly move the position (cursor) of the modified data, which makes the operation more efficient. Press the key  to save the modified parameter value and display the next parameter, keep pressing the key  to quickly go down; press and hold the key  for more than 2 seconds to return to the display of the previous parameter; press and hold the key  first and then press the key  again to exit the parameter setting state directly; if there is no key operation, it will automatically return to the basic display state after about 25 seconds.

3.4.2 Quick Operating Instructions





All functions of the AI-8 series can be completed by modifying parameters, but for some commonly used functions, such as modifying the given value and running/stopping the program, we have designed shortcut operations to simplify the use. The convenience mode can also be set to prohibit use to prevent misoperation.

Given value setting: If the instrument uses the fixed-point control mode (parameter Pno=0), in the basic display state where the lower display window displays the given value (If the lower display window displays the output value, press the key  to switch to the given value display state, the same below), press the key  to enter the state of modifying the current given value, and then press the , ,  and other keys to directly modify the given value.

Program setting: The instrument uses program control mode (parameter Pno≥1), in the state that the lower display window displays the given value, press the key  to enter the program setting state, the given value of the current running segment is displayed first, and the next data can be displayed by pressing the key , each program is arranged in the order of "given value-time-given value". Programs can be modified even while the program is running.

Running control: When it is necessary to start the running control, press the key  and hold it for about 2 seconds so that the lower display of the instrument displays the "run" symbol. AI-8 series will start the program operation in the stopped state. For AI-8 series and the parameter PAF.F=1, if the program of the instrument is already in the running state, the operation will enter the hold running (HoLd) state, and the time will be paused in this state, and the *run* operation will be executed again. Normal operation can be resumed.

Stop control: In the state that the lower display window displays the given value, press the key  for about 2 seconds so that the lower display will display the "StoP" symbol, and the instrument stops controlling the output. AI-8 series stops the program running, and the parameter StEP of the block number is modified to 1.

Automatic/manual control switching (A/M): In the state where the lower display window displays the output value (if the lower display window displays the given value, press the key  to switch to the output value display state), press the A/M key () to make the instrument switch between automatic and manual without disturbance. In the manual state and the output value is displayed in the lower display window, directly press  or  to increase and decrease the manual output value. By setting the A-M parameters, the instrument can also be fixed in the automatic

state and not allowed to be switched to the manual state by the operation of the panel keys, so as to prevent entering the manual state by mistake.

Auto-tuning AT: Press and hold \triangleleft for 2 seconds, the *At* parameter will appear, press \triangle to change the *OFF* of the lower display window to *on*, and then press \curvearrowright to confirm to start the self-tuning function. The lower display of the instrument will flash and display the word "*At*", and the instrument can automatically calculate the PID parameters after 2 oscillation cycles of ON-OFF control. If the auto-tuning is determined to be given up in advance, press \triangleleft again and hold it for about 2 seconds to call up the *At* parameter, and set *on* to *OFF*, and then press \curvearrowright to confirm. If the instrument is running, auto-tune will cause the program timing to be paused to ensure that the given value does not change. In the system with heating/cooling bidirectional output, it is necessary to separate two groups of tuning PID parameters. When the instrument control is in the AUX cold output, start *At*, and then automatically tune the cold output parameters such as P2, I2, and d2.

Quick self-tuning function AAT: Press \triangleleft and hold it for 2 seconds, the *At* parameter will appear, press \triangle to change the *OFF* of the lower display window to *AAt*, and then press \curvearrowright to confirm, on this condition, When the instrument is in full power heating output state after power-on, *AAT*'s advanced fast parameter self-tuning function is automatically activated, and PID parameters can be set in advance without the need for traditional periodic oscillation self-tuning. In most cases, accurate control can be achieved by heating for the first time. If the *AAT* does not automatically complete the instrument and exits the full power output state, the *AAT* fails, and the rapid auto-tuning is terminated, and the PID parameters will not be modified; next time the instrument is in full power heating output state, the *AAT* function will be activated again. When *AAT* is fast self-tuning, the lower display of the instrument will flash and display the word "*AAT*". After the end, the *At* parameter will automatically return to *OFF*.

Manual auto-tuning: Since auto-tuning is performed with positional adjustment, its output will be positioned at the position defined by parameters OPL and OPH. In some occasions where the output is not allowed to change greatly, such as where some actuators use control valves, conventional self-tuning is not suitable. In this regard, AI-8 series instruments have manual self-tuning mode. The method is to adjust manually first, and after the manual adjustment is basically stable, start auto-tuning in manual state, so that the output value of the instrument will be limited to the range of +10% and -10% of the current manual value instead that of OPL and OPH, which avoids the phenomenon of large valve changes that are not allowed on the production site. In addition, when the controlled physical value responds quickly, the manual self-tuning method can obtain more accurate self-tuning results. Note: Before the manual auto-tuning is started, the manual output value should be within the range of 10%~90%, and the measured value and the given value should be basically consistent and stable, otherwise the correct parameters will not be set.

Note 1: AI-8 series adopts advanced PID adjustment algorithm integrated with AI artificial intelligence technology, which solves the problem of easy overshoot of standard PID algorithm and has high control accuracy. We call this improved PID algorithm the APID algorithm. When the instrument chooses APID or PID adjustment mode and is used for the first time, the self-tuning function can be activated to assist in determining PID and other control parameters.

Note 2: The parameter values obtained by the system tuning under different given values are not exactly the same. Before executing the auto-tuning function, the given value SV should be set to the most commonly used value or the middle value, if the system is an electric furnace with good heat preservation performance, the given value SV should be set at the maximum value used by the system, and it is forbidden to modify the SV value during the self-tuning process. Depending on the system, the time required for auto-tuning can vary from seconds to hours.

Note 3: The control hysteresis parameter *CHYS* also affects the auto-tuning results. Generally, the smaller the setting value of *CHYS*, the higher the accuracy of the auto-tuning parameters. However, if the *CHYS* value is too small, it may cause the misoperation of the bit adjustment due to the input fluctuation, which may set completely wrong

parameters. CHYS=2.0 is recommended.

Note 4: The control effect may not be the best at the end of self-tuning. Due to the self-learning function, the best effect can be obtained after a period of use.

Note 5: In the auto-tuning or manual state, the control period (parameter Ctl) of the instrument is temporarily limited to no more than 3 seconds no matter how large the original setting is, aiming to improve the tuning accuracy and the response speed of the instrument during manual operation.

3.4.3 Instructions for E5 Rail Mounted Instruments

AI-8 E5 rail-mounted instrument itself has no display and keyboard. It can install an RS485 communication interface, and use the connection with the upper computer or touch screen to complete the function and operation of its display interface, or use an external E85 keyboard and monitor for display and parameter setting. E85 supports hot swapping, that is, it can be hand-held or installed on DIN rails. E5 has double-row 4-digit digital display, but there is no LED indicator, its operation and display are fully compatible with panel mounted instrument. Each time the LED indicator of the E5 instrument flashes when it communicates with the upper computer in the instrument, it means that it communicates with the upper computer once. If the meter does not receive a signal from the host computer within 6 seconds, then it will flash on/off with equal time, and its meaning are as follows:

When the indicator light flashes slowly with a cycle of 1.6 seconds, it means that although there is no communication, the instrument is working normally without an alarm.

When the indicator light flashes quickly with a cycle of 0.6 seconds, it means that the instrument has no communication, and there is a general error such as an alarm.

When the indicator light flashes rapidly with a cycle of 0.3 seconds, it means that there is no communication and there are serious errors such as input overrange (such as thermocouple, thermal resistance open circuit).

If the indicator light is always off, it means that the instrument is out of power or damaged; if the indicator light is always on (more than 8 seconds), it means that the instrument is powered on but it is damaged.

4.Parameter Description

4.1 Typical Setting Process and Common Parameters

① Please refer to the complete parameter table for the description of the parameters in the figure. For other functions, please refer to the description of common functions.

② The input range does not need to be set when the thermocouple or thermal resistance is selected for the input specification, and the range is set only when the analog signal input or the transmission function is required.

③ Auto-tuning is only required when APID or nPID is selected as the control mode. Auto-tuning must be performed when the equipment can work normally.

④ After the setting, if the instrument is in the stop or pause state, it needs to run manually or the upper computer executes the running command.

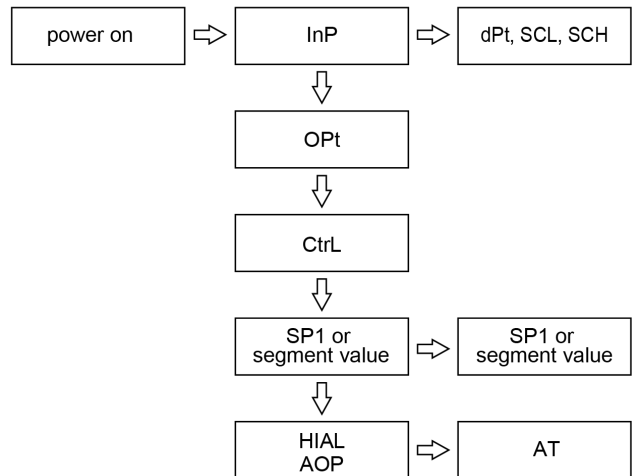

4.2 Parameter Lock and Custom Parameter Table

4.2.1 Parameter Lock(Loc)

Loc can provide a variety of different parameter operation authority and password input operation to enter the complete parameter table, and its functions are as follows:

Loc=0, allowed to modify the field parameters, and allowed to directly modify the given value in the basic display state;

Loc=1, it is forbidden to modify the field parameters, and it is allowed to directly modify the given value in the basic display state;

Loc=2~3, it is allowed to modify the field parameters, but it is forbidden to directly modify the given value in the basic display state;

Loc=4~255, any parameters other than Loc are not allowed to be modified, and all shortcut operations are also prohibited;

Set Loc=password (the password can be a number between 256~9999, the initial password is 808), and press

 to confirm, it is able to have access to display and modify the complete parameter list. Once the complete parameter list is entered, all parameters except read-only parameters are authorized to be modified. The Loc parameter can also set the communication write limit, please refer to the description of the communication protocol for details; the manual/automatic function and the AT function are independently set and controlled.

4.2.2 Custom Parameter Table

The parameter table of AI-8 can be programmed to define the function, which means the parameter table of the instrument can be customized for you. In order to protect important parameters from being arbitrarily modified, we call

the parameters that need to be displayed or modified in the field as field parameters. The field parameter table is a subset of the complete parameter table and can be defined by the user, and can be directly called out for the user to modify, while the complete constant table must be called out under the condition of entering a password.

Parameters EP1~EP8 allow users to define 1~8 field parameters. If the field parameters are less than 8, the first parameter that is not used should be defined as nonE. For example: the parameter table we need has three parameters such as HIAL, HdAL and At, and the EP parameters can be set as follows: EP1=HIAL, EP2=HdAL, EP3=At, EP4=nonE.

4.3 Complete Parameter Table

The complete parameter table is divided into 8 blocks, including alarm, adjustment control, input, output, communication, system function, given value/program and field parameter definition, etc. The parameters are as follows:

Parm.	Meaning	Description	Range
Addr	Postal address	The Addr parameter defines the instrument communication address and has a valid range of 0-80. Instruments on the same communication line should have a different Addr value to distinguish them from each other.	0~99
bAud	Baud rate	The bAud parameter defines the communication baud rate, ranging from 0 to 28800bit/s (28.8K); When COM location is not used for communication function, COM port can be used as other function by bAud parameter setting: bAud=0, COMM slot transmitted as a set value of 0-20ma for output; bAud=1, as an external switching value input, has the same function as the MIO position. When the MIO position is occupied, the I2 module can be installed in the COMM position. bAud=3, the COMM port is used for transmission and output function of the 0~20mA measurement value; bAud=4, the COMM port is used for transmission and output function of the 4~20mA measurement value ; bAud=8, the COMM port is used for transmission and output function of the 0~20mA set value; bAud=12, the COMM port is used for transmission and output function of the 4~20mA set value.	0~28.8K
AFC	communication mode	Select communication mode, its calculation method is as follow: $AFC=A*1+D*8+G*64$ A=0, standard MODBUS; A=1, AIBUS; A=2, MODBUS compatible mode; A=4, compatible with S6 module. D=0, no calibration; D=1, even calibration. G=0, AUX used normally; G=1, AUX used as event input. Note: AFC supports 03H (read parameters and data) and 06H (write a single parameter) under MODBUS. When AFC=0 or 4, the 03H can read up to 20 words at a time; When AFC=2, 03H reads 4 words. For more details, Please refer to the communication protocol description.	0~255

InP InP	Enter specification code	InP is used to select the input specification, and the input specification corresponding to its value is as follows:		0~106
		0 K	21 Pt100	
		1 S	22 Pt100 (-80.00~+300.00℃)	
		2 R	25 0~75mV voltage input	
		3 T	26 0~100Ω resistance input	
		4 E	27 0~400Ω resistance input	
		5 J	28 0~20mV voltage input	
		6 B	30 0~60mV voltage input	
		7 N	31 0~1V voltage input	
		8 WRe3-WRe25	32 0.2~1V voltage input	
		9 WRe5-WRe26	33 1~5V voltage input	
		10 User-specified extended input specification	34 0~5V voltage input	
		12 F2 Radiation Pyrometer	35 -20~+20mV voltage input	
		13 T (0~300.00℃)	37 -5V~+5V voltage input	
		15 MIO input 1(4~20mA, installing I44)	42 0~10V voltage input	
		16 MIO input 2(4~20mA, installing I44)	43 2~10V voltage input	
		17 K (0~300.00℃)	44 -10V~+10V voltage input	
		18 J (0~300.00℃)	45 0~100mV voltage input	
		19 Ni120	46 20~100mV voltage input	
		20 Cu50		
Note: When InP=10 is set, the non-linear table can be entered by yourself, or the manufacturer can enter it for a fee.				
AOP AOP	Alarm output definition	<p>The 4-digit ones, tens, hundreds and thousands of AOP are used to define the output positions of 4 alarms such as HIAL, LoAL, HdAL and LdAL, as follows:</p> <p style="text-align: center;">AOP = <u> 3 </u> <u> 3 </u> <u> 0 </u> <u> 1 </u> ; LdAL HdAL LoAL HIAL</p> <p>The value range is 0-9, 0 means that the alarm is not output from any port, 1, 2, 3, 4 means that the alarm is output by AL1, AL2, AU1, and AU2, respectively; Value 5, 6, 7 and 8 refers that alarms are assigned to AL1, AL2, AU1 or AU2 and the main output are set to zero mandatorily or a value defined by Ero (configured via AF2). Value 9 refers the main output are set to zero mandatorily or a value defined by Ero (configured via AF2) without any alarm.</p> <p>For example, if AOP=3301 is set, it means that the upper limit alarm HIAL is output by AL1, the lower limit alarm LoAL is not output, and HdAL and LdAL are output by AU1.</p> <p>Note 1: When AUX is used as auxiliary output in the two-way adjustment system, the output of alarm designated AU1 and AU2 is invalid.</p> <p>Note 2: If AL2 or AU2 is used, the L3 two-way relay module can be installed at the ALM or AUX position.</p>		0~9999

<p>OPt □P□</p>	<p>output type</p>	<p>SSr, to output SSR driving voltage or SCR zero crossing trigger time proportional signal, modules G, K1 or K3 shall be installed respectively, and the output power shall be adjusted by adjusting the on-off time ratio, with a period of 0.5-4.0 seconds.</p> <p>rELy, when the output is a relay contact switch or there is a mechanical contact switch in the actuating system (such as a contactor or compressor), this setting should be used. To protect the mechanical contact life, the system limits the output cycle to 3-120 seconds.</p> <p>0-20, 0~20mA linear current output, X3 or X5 linear current output module shall be installed.</p> <p>4-20, 4~20mA linear current output, X3 or X5 linear current output module shall be installed.</p> <p>PHA1, single-phase phase-shift output, K50/K60 phase-shift trigger output module shall be installed to realize phase-shift trigger output. In this setting state, AUX cannot be used as the cold output end of the regulating output.</p> <p>nFEd, position proportional output without feedback signal, directly controls forward/reverse rotation of valve motor, and valve travel time is defined by Strt parameter.</p> <p>FEd, position proportional output with feedback signal, the valve travel time should be more than 10 seconds, and the feedback signal is input from the 0~5V/1~5V input end of the instrument. Note: In this output mode, externally given functions can no longer be used.</p> <p>FEAt, automatically adjust the valve position. The instrument will first close the valve and record the feedback signal in the SPSL parameters, then fully open the valve to memorize the valve feedback signal in the SPSH parameters, and then automatically return to the FEd control mode.</p> <p>Note: AI-8* 6 series doesn't possess position proportional control output</p>	
<p>At AT</p>	<p>Auto tuning</p>	<p>OFF, the auto tuning At function is off.</p> <p>on, start PID and Ctl parameter auto-tuning function, and automatically return to FOFF after auto-tuning.</p> <p>FOFF, the auto-tuning function is closed, and it is prohibited to start the auto-tuning from the panel operation.</p> <p>AAAt, fast auto-tuning function, automatically returns to OFF after auto-tuning.</p> <p>Note: AAAt option is selected for At parameter. When the instrument is in the full power heating output state after power on, the advanced AAAt fast parameter auto-tuning function can be automatically started. PID parameters can be set in advance without traditional periodic oscillation auto-tuning. In most cases, accurate control can be achieved for the first heating. If AAAt exits the full power output state before automatically completing the instrument, AAAt fails, the auto-tuning is terminated, and the PID parameters will not be modified.</p>	

<p>A-M R-ii</p>	<p>Automatic/manual control selection</p>	<p>MAn: manually controls the state, and the operator manually adjusts the output of OOTP.</p> <p>Auto: automatically control status, OOTP output is determined by Ctrl after calculation.</p> <p>FSv: is compatible with the manual automatic function instrument mode, and it is prohibited to enter the manual automatic switching interface.</p> <p>FAut: is in fixed automatic control state, which prohibits direct key operation from front panel to manual state.</p>	
<p>Srun Srun</p>	<p>Running state</p>	<p>Run, running control status, PRG light is on.</p> <p>Stop, stop state, the lower display flashes show "Stop", and the PRG light is off.</p> <p>HoLd, keep the operation under control state. If the instrument is thermostatically controlled for unlimited time (when Pno=0), this state is equivalent to the normal operation state, but it is prohibited to run or stop from the panel. If the instrument is under program control (Pno>0), the instrument will maintain the control output under this state, but the timing will be suspended. At the same time, the lower display will flash to display "HoLd" and the PRG light will flash. The panel keys can be used to execute the operation control or stop to release the operation status.</p>	
<p>Pno Pno</p>	<p>Numbers of program segments</p>	<p>It is used to define the number of effective program segments, which can reduce the number of unnecessary program segments as needed, so that the operation and program settings are convenient for the end user. When Pno=0 is set, the instrument is in constant temperature mode; At the same time, SPr parameters can also be set to limit the heating rate; When Pno=1 is set, it is a single program mode. Only one set value and one holding time need to be set, and the holding time will end and enter the stop state; When Pno=2~50 is set, normal program control instrument operation mode is adopted for operation.</p> <p>Note: 8* 6 series only supports one program segment.</p>	<p>0~50</p>
<p>PonP PonP</p>	<p>Power-on automatic operation mode</p>	<p>Cont, if it is stopped before power failure, continue to stop; otherwise, continue to execute at the original termination after the instrument is powered on.</p> <p>Stop, no matter what happens after power on, the instrument will enter the stop state.</p> <p>Run1. If it is stopped before power failure, it will continue to stop; otherwise, the program will automatically start running from the first section after power failure.</p> <p>dASt, after power on, if there is no deviation alarm, the program will continue to execute; if there is deviation alarm, the program will stop running.</p> <p>HoLd (only when Pno ≥ 1), the instrument is powered off during operation. No matter what happens after the power is on, the instrument will enter the suspend state. However, if the instrument is stopped before power failure, it will remain stopped after power on.</p>	

<p>Et Et</p>	<p>Event Input Type</p>	<p>The Et parameter has been extended to 2 inputs (modules such as I5 need to be installed if dual inputs are used), $Et=Et1 * 10+Et2$, where Et1 and Et2 represent event input 1 and input 2, respectively. The numerical meanings of Et1 or Et2 are as follows:</p> <p>0(nonE): Disable event input function.</p> <p>1(ruSt): Run / Stop switching function. Connected in short time, start to run program, keep connect more than 2 sec, program switch to stop.</p> <p>2(SP1.2): Switching set value under set point regulation(Pno=0); when MIO in open status, SV=SP1; when MIO in close status, SV=SP 2.</p> <p>3(PId2): When used as single direction control, MIO in open status, P, I, d and Ctl are active; when MIO in close status, P2, I2, d2 and Ctl2 are active</p> <p>4(EAct): External switch to switch the heating/cooling. When MIO turns off, parameters P, I, d and Ctl are used for heating regulation. When MIO turns on, parameters P2, I2, d2 and Ctl2 are used for cooling regulation.</p> <p>5 (Eman): External switch to switch between manual/automatic. Instrument in automatic mode when switch is off and in manual mode when switch is on.</p> <p>6(Erun): External switch to RUN/STOP. Instrument stops when switch is off and runs when switch is on.</p> <p>7(Eout): Forces the main output to be 0 or Ero when the external switch turns on. (Based on the AF2. E parameter function).</p> <p>Note: If Et1=Et2 is set, the system will execute Et1 first and then Et2, and the result will be based on Et2.</p>	<p>0-77</p>
<p>Ctrl Ctrl</p>	<p>Control mode</p>	<p>OnoF, which adopts position adjustment (ON-OFF), is only suitable for control in low requirements.</p> <p>APID, an advanced AI artificial intelligence PID adjustment algorithm, is recommended.</p> <p>NPID, standard PID regulation algorithm, has anti-saturation integration function.</p> <p>PoP, which directly takes PV value as output value, can make the instrument become a temperature transmitter.</p> <p>SoP, the SV value is taken as the output value directly. When Pno \geq 1, the instrument becomes a program generator.</p>	

OPL OPL	Output lower limit	<p>When it is set to 0~100%, it is used as the minimum limit value of regulating output OUTP in normal one-way regulation.</p> <p>When the setting is - 1~- 110%, the instrument becomes a two-way output system with heating/cooling dual output function. When the Act is set to rE or rEbA, the main output OUTP is used for heating and the auxiliary output AUX is used for cooling. On the contrary, when the Act is set to dr or drbA, OUTP is used for cooling and AUX is used for heating.</p> <p>When the instrument is a two-way output, OPL is used to reflect the maximum cold output limit. When OPL=- 100%, there is no limit on cold output. - 110% can make the current output, such as (4~20mA), exceed the maximum range by more than 10%. It is suitable for special occasions. When SSR or relay outputs, the maximum cold output limit should not be more than 100%.</p>	-110~ +110%
OPH OPH	Output upper limit	<p>When the measured value PV is less than OEF, limit the maximum output value of the main output OUTP, and when PV is greater than OEF, the system corrects the upper limit of the output to 100%; In the proportional output without feedback position (when OPt=nFEd), if OPH is less than 100, the instrument will automatically set the valve position when powered on; if OPH=100, the instrument will automatically set the valve position when the output is 0% and 100%, which can shorten the power on and startup time. The OPH setting must be greater than OPL.</p>	0~110%
Aut Aut	Cooling output type	<p>The AUX output type is defined only when AUX is used as an auxiliary output in the heating/cooling two-way regulation.</p> <p>SSr, output SSR driving voltage or SCR zero crossing trigger time proportional signal, install G or K1 modules respectively, and adjust the output power by adjusting the on-off time ratio, with a period of 0.5-4.0 seconds.</p> <p>rELy, when the output is a relay contact switch or there is a mechanical contact switch in the actuating system (such as a contactor or compressor), this setting should be used. To protect the service life of mechanical contacts, the system limits the output cycle to at least 3-120 seconds, generally 1/5-1/10 of the system delay time.</p> <p>0-20, 0~20mA linear current output, X3 or X5 linear current output module shall be installed on AUX.</p> <p>4-20, 4-20mA linear current output, X3 or X5 linear current output module shall be installed on AUX.</p> <p>Note: If the OPt or Aut output is set to rELy, the output cycle is limited to 3-120 seconds in principle. If the heating or refrigeration output signal is 4-20mA, when the heating is output, the refrigeration output signal will return to zero, and the output is 0mA instead of 4mA; When there is an output of refrigeration, the signal at the heating output terminal is zero, and the output is 0mA instead of 4mA.</p>	

CHYS [HY5]	Control return difference (dead zone, hysteresis)	<p>It is used to avoid frequent action of ON-OFF position regulating output relay.</p> <p>It is used to avoid frequent action of ON-OFF position regulating output relay.</p> <p>When it is used for reaction (heating) control, the relay is turned off when PV is greater than SV, and the output is switched on again when PV is less than SV-CHYS; When it is used for positive action (refrigeration) control, the output is turned off when PV is less than SV, and turned on again when PV is greater than SV+CHYS.</p>	0~9999unit
Act Rct	Positive/negative reaction	<p>rE is a reaction regulation mode. When the input increases, the output tends to decrease, such as heating control.</p> <p>dr is a positive regulation mode. When the input increases, the output tends to increase, such as refrigeration control.</p> <p>rEbA, a reaction regulation, and has the functions of power-on exemption from lower limit alarm and deviation lower limit alarm.</p> <p>drbA, a positive adjustment mode, and has the functions of power-on exemption from upper limit alarm and deviation upper limit alarm.</p>	
P P	Proportional band	<p>Define the proportional band adjusted by APID and PID, and the unit is the same as the PV value, rather than the percentage of the range.</p> <p>Note: The At function is usually used to determine P, I, D and Ctl parameter values, but for familiar systems, such as batch-produced heating equipment, the known correct P, I, D, Ctl parameter values can be directly entered.</p>	1~32000unit
I I	Integral Time	Defines the integral time adjusted by PID, in seconds, when I=0, the integral action is canceled.	0~9999s
d d	Differential time	Defines the differential time adjusted by PID, in 0.1 seconds. When d=0, the differential action is canceled.	0~3200s
Ctl [Et]	Control cycle	<p>When SSR, thyristor or current output is used, it is generally set to 0.5-3.0 seconds. When relay switch is used for output or heating/cooling dual output control system is used for output, short control cycle will shorten the service life of mechanical switch or lead to frequent switching and starting of cold/hot output. If the cycle is too long, the control accuracy will be reduced. Therefore, it is generally between 15-40 seconds. It is recommended that Ctl be set to about 1/5-1/10 of differential time (basically equal to the lag time of the system).</p> <p>When the output is a relay switch (OPT or Aut is set to rELY), the actual Ctl will be limited to more than 3 seconds, and the auto setting At will automatically set the Ctl to a suitable value to give consideration to the control accuracy and mechanical switch life.</p> <p>If the output is a control valve, Ctl is recommended to be 3~15s, giving consideration to response speed and avoiding frequent valve action.</p> <p>When the regulation mode parameter Ctrl is defined as the ON-OFF mode, Ctl defines the delay time of ON action after the output is disconnected or powered on to avoid being connected immediately after disconnection. This function is intended to protect the operation of the compressor.</p>	0.2~300.0s

P2 P2	Cold output proportional band	Define the cold output proportional band adjusted by APID and PID, and the unit is the same as the PV value, rather than the percentage of the range.	1~32000 unit
I2 I2	Cold output integration time	Define the integral time of cold output adjusted by PID, in seconds, and the integral action is canceled when I=0.	0~9999s
d2 d2	Cold output differential time	Define the differential time of cold output adjusted by PID, in 0.1 seconds. When d=0, the differential action is canceled.	0~3200s
Ctl2 Ctl2	Cold output cycle	When SSR, thyristor or current output is used, it is generally set to 0.5-3.0 seconds. When the output is a relay switch (OPt or Aut is set to rELY), the actual Ctl will be limited to more than 3 seconds, generally 20~40 seconds.	0.2~ 300.0s
dPt dPt	Position of decimal point	<p>Four display formats can be selected: 0, 0.0, 0.00 and 0.000.</p> <p>Note 1: For general thermocouple or thermal resistance input, 0 or 0.0 can be selected. Even if the 0 format is selected, the internal resolution of 0.1 °C is still maintained for control calculation. When using S, R and B thermocouples, it is recommended to select the 0 format; When INP=17, 18, 22, the internal resolution of the instrument is 0.01 °C, and two display formats, 0.0 or 0.00, can be selected.</p> <p>Note 2: When using linear input, if the measured value or other relevant parameter values may be greater than 9999, it is recommended not to use the 0 format but the 0.000 format, because the display format will change to 00.00 after the value is greater than 9999.</p>	
Scb Scb	Input translation correction	The Scb parameter is used for translation correction of input to compensate the error of sensor, input signal, or thermocouple cold end automatic compensation. Note: Generally, it should be set to 0. Incorrect setting will lead to measurement error.	-9990~ +4000 unit
SCL SCL	Enter lower scale limit	It is used to define the lower limit scale value of linear input signal and also to define the lower limit scale of the signal when the instrument is displayed as the transmitting output or light column display.	-9990 ~ +32000 unit
SCH SCH	Enter upper scale limit	It is used to define the upper limit scale value of the linear input signal, and also to define the upper limit scale of the signal when the instrument is used as the transmission output or light column display.	
FILT FILT	Input digital filtering	FILT determines the digital filtering strength. The larger the setting, the stronger the filtering, but the slower the response speed of the measured data. When the measurement is greatly disturbed, increase FILT gradually to make the instantaneous runout of the measured value less than 2~5 words. When the instrument is calibrated, set FILT to 0 or 1 to improve the response speed. The unit of FILT is 0.5 second.	0~40

<p>Fru FrU</p>	<p>Power frequency and temperature Unit-selection</p>	<p>50C means that the power frequency is 50Hz, and the input has the maximum anti-interference capability to this frequency; The unit of temperature is ℃ .</p> <p>50F means that the power frequency is 50Hz, and the input has the maximum anti-interference capability to this frequency; The temperature is in ° F.</p> <p>60C means that the power frequency is 60Hz, and the input has the maximum anti-interference capability to this frequency; The unit of temperature is ℃ .</p> <p>60F means that the power frequency is 60Hz, and the input has the maximum anti-interference capability to this frequency; The temperature is in ° F.</p>	
<p>SPSL SPSL</p>	<p>Lower limit of external given scale</p>	<p>It is used to define the lower limit of scale of external given input signal when external given function is used; The lower limit of the valve position feedback signal is defined when the position proportional output is used, and the parameter can be automatically set by the valve auto-tuning function.</p>	
<p>SPSH SPSH</p>	<p>Upper limit of external given scale</p>	<p>It is used to define the upper limit of external given input signal scale when external given function is used; The upper limit of the valve position feedback signal is defined when the position proportional output is used, and the parameter can be determined by the valve auto-tuning function.</p> <p>Warning: The value of valve position after auto-setting is only for display and reference. Unless professionals, please do not manually modify SPSH and SPSL parameters.</p>	<p>-9990 ~ +32000 unit</p>
<p>AF RF</p>	<p>Advanced function code</p>	<p>AF parameter is used to select advanced functions, and its calculation method is as follows:</p> $AF=A \times 1+B \times 2+C \times 4+D \times 8+E \times 16+F \times 32+G \times 64+H \times 128$ <p>A=0, HdAL and LdAL are deviation alarms; A=1, HdAL and LdAL are absolute value alarms, so the instrument can have two absolute value upper limit alarms and absolute value lower limit alarms respectively.</p> <p>B=0, the return difference of alarm and position adjustment is unilateral return difference; B=1, refers to bilateral backlash.</p> <p>C=0, the third row of instrument has a decimal point; C=1, there is no decimal point in the third row of the instrument (only the third row display is available).</p> <p>D=0, the password of entering the parameter table is public 808; D=1, the password is the parameter PASd value. Switch to on-site parameters and long press the left key to find LOC.</p> <p>E=0, HIAL and LOAL are absolute value upper limit alarm and absolute value lower limit alarm respectively; E=1, HIAL and LOAL are changed to upper limit and lower limit deviation alarms respectively, so there are four deviation alarms.</p> <p>F=0, fine control mode, internal control resolution is 10 times of the display, but the maximum display value is 3200 units in linear input; F=1 is the high resolution</p>	<p>0~255</p>

<p>AF RF</p>	<p>Advanced function code</p>	<p>display mode, which is selected when the display value is required to be greater than 3200.</p> <p>If G=0, the upper limit alarm is allowed when the measured value increases due to sensor disconnection (the upper limit alarm setting value should be less than the upper limit of signal range); G=1, the increase of measured value caused by sensor disconnection does not allow upper limit alarm. Please note that in this mode, even the normal upper alarm limit (HIAL) will delay about 15 seconds before it acts.</p> <p>H=0, HIAL and LOAL are independent alarm logic; If H=1, HIAL and LOAL become interval alarm, and only when LOAL>PV>HIAL is met, the alarm will be given. The alarm code is HIAL, and HIAL is also used for output.</p> <p>Note: For non-professional users, this parameter can be set to 0.</p>	<p>0~255</p>
<p>AF2 RF2</p>	<p>Advanced function code 2</p>	<p>AF2 is used to select the second group of advanced function codes, and its calculation method is as follows:</p> $AF2=A \times 1 + B \times 2 + C \times 4 + D \times 8 + E \times 16 + F \times 32 + G \times 64 + H \times 128$ <p>A=0, the given value is internally given; A=1, the given value is external given, and the external given signal is input from the 5V input terminal.</p> <p>B = 0, the external given signal is 1~5V; B = 1, the external given signal is 0~5V.</p> <p>C=0, normal input mode; C=1, the linear input signal is squared.</p> <p>D=0, the transmitting output uses SCH SCL to define the scale; D=1, the transmission output uses SPSL SPSH to define the scale (Note: Do not use the valve feedback signal input).</p> <p>E=0, output 0 when sensor is disconnected, E=1, the Ero parameter is output when the sensor is disconnected.</p> <p>F=0, the system automatically sets Ero, F=1, set Ero manually. Automatic definition of Ero is one of the contents of AI auto-learning control, that is, the instrument will automatically memorize the average output value when the measured value is consistent with the given value, which can be used for PID adjustment operation as a reference to improve the control effect. For safety, the maximum learning value of Ero is 70% of the output power. If a higher value of Ero is required, it should be set as the safest common output when Ero parameters can be manually set.</p> <p>G=0, standby.</p> <p>H=0, CT function is disabled; The CT measurement function must be disabled during position proportional output (valve motor servo) to avoid conflicts between the two; H=1, the CT function is activated and needs to work with I9 module to detect current, which can be used for judging load disconnection or actuator short circuit.</p> <p>Note: The AI-8 * 6 series does not support external functions.</p>	<p>0~255</p>

<p>PAF PRF</p>	<p>Program operation mode (Pno≥1)</p>	<p>PAF parameter is used to select program control function, and its calculation method is as follows: $PAF=A \times 1 + B \times 2 + C \times 4 + D \times 8 + E \times 16 + F \times 32 + G \times 64 + H \times 128$ A=0, the preparation function (rdy) is invalid; A=1, the preparation function is effective. B=0, slope mode, when there is temperature difference during program operation, different temperature rise modes can be defined according to broken line transition, and it can also be used for cooling operation; B=1, platform mode (constant temperature mode), each segment of the program defines the given value and holding time, reaching the conditions of the next segment can be limited by the rdy function, and the rising/cooling rate can be limited by the SPPr/SPPrL parameter; in addition, even if B=0 is set, if the last segment of the program is not the end command, the constant temperature mode will also be executed, and the time will automatically end. C=0, the program time is in minutes; C=1, time is in hours. D=0, without measurement value activation function; D=1, with measurement value activation function. E=0, displays the measured value as a window when the program gives the generator; E=1, displays the program segment number as a window when the program gives the generator. F=0, standard operation mode; F=1, when the program is running, the RUN operation will enter the HoLd state. G=0, the program time is in minutes; G=1, the time is in seconds. H=0, standard operation mode; H=1, each segment has preparation function (rdy) in slope mode.</p>	<p>0~255</p>
<p>SPPr SPPr</p>	<p>Temperature -rising rate limit</p>	<p>When SPPr is set as valid, the program runs or the set value is changed, and the measured value is lower than the set value, the instrument will rise to the set value at the temperature rise rate limit defined by SPPr. The PRG light will flash under the temperature rise rate limit state. SPPr is valid for fixed point control (Pno=0) and program platform mode, but not for slope mode. When item C of PAF=1, the units of SPPr and SPPrL become °C/hour.</p>	<p>0~3200 °C/ min</p>
<p>SPPrL SPPrL</p>	<p>Cooling rate limit</p>	<p>When SPPrL is set as valid, the program runs or the set value is changed, and the measured value is higher than the given value, the instrument will cool down to the given value with the limit value of the cooling rate defined by SPPrL. In the cooling rate limit state, the PRG light will flash. SPPrL is valid for fixed-point control (Pno=0) and program platform mode, but not for slope mode. If the system has no refrigeration output, when the natural cooling rate is lower than SPPrL, the instrument cannot guarantee the cooling slope, so it will be cooled at the natural cooling rate. When item C of PAF=1, the units of SPPr and SPPrL become °C/hour.</p>	<p>0~3200 °C/ min</p>

Ero Ero	Output value at excessive range	<p>When the instrument control mode is PID or APID, Ero defines the output value to be adjusted when the input is over range (usually caused by sensor failure or disconnection).</p> <p>AF2 parameter can define whether the Ero is valid and the setting mode. When the Ero is defined as the automatic setting mode and the deviation is less than 4 measurement units, the instrument automatically stores the integral output value, so the Ero value will automatically change with the system.</p> <p>When the mode is set manually, the Ero value is set manually.</p>	-110 ~110%
OPrt OPrt	Output soft start time	<p>If PV is less than OEF when the instrument is powered on or stopped, the maximum allowable output of main output OUTP will rise to 100% after OPrt. If PV is less than OEF when the instrument is powered on or stopped, the maximum allowable output of main output OUTP will rise to 100% after OPrt.</p>	0~3600s
OEF OEF	Effective range of OPH	<p>When the measured value PV is less than OEF, the upper limit of output OUTP is OPH, yet when PV is greater than OEF, the regulator output is not limited to 100%.</p> <p>Note: This function is used in some occasions where full power heating is not possible at low temperature. For example, because of the need to dry the moisture in the furnace or to avoid too fast temperature rise, a heater only allows 30% of the maximum heating power when the temperature is lower than 150 °C, then it can be set: OEF=150.0 (°C), OPH=30 (%).</p>	-999.0 ~ +3200.0 °C or linear unit
HIAL HIAL	Upper limit alarm	<p>When the measured value PV is greater than the HIAL value, the instrument will generate an upper limit alarm; When the measured value PV is less than the HIAL-AHYS value, the instrument will remove the upper limit alarm.</p> <p>Note: Each alarm can be freely defined as controlling the action of output ports such as AL1, AL2, AU1 and AU2, or not doing any action. Please refer to the description of alarm output definition parameter AOP.</p>	-9990~ +32000 unit
LoAL LoAL	Lower limit alarm	<p>When PV is less than LoAL, the lower limit alarm will be generated, and when PV is greater than LoAL+AHYS, the lower limit alarm will be released.</p> <p>Note: HIAL and LoAL can also be set as deviation alarm if necessary (see AF parameter description).</p>	
HdAL HdAL	Deviation upper limit alarm	<p>When the deviation (measured value PV - given value SV) is greater than HdAL, the deviation upper limit alarm will be generated; When the deviation is less than HdAL-AHYS, the alarm will be released. When HdAL is set to the maximum value, the alarm function is canceled.</p>	
LdAL LdAL	Deviation lower limit alarm	<p>When the deviation (measured value PV - given value SV) is less than LdAL, the deviation lower limit alarm will be generated. When the deviation is greater than LdAL+AHYS, the alarm will be released. When LdAL is set to the minimum value, the alarm function is canceled.</p> <p>Note: If necessary, HdAL and LdAL can also be set as absolute value alarm (please refer to AF parameter description).</p>	

AHYS RHYS	Alarm return difference	Also known as alarm dead zone, hysteresis, etc., it is used to prevent the alarm critical position from frequently acting due to the alarm relay. Please refer to the above.	0~2000 unit
AdIS RdIS	Alarm indication	<p>OFF, the alarm symbol is not displayed at the lower display during alarm.</p> <p>On, in case of alarm, the alarm symbol is alternately displayed on the lower display as a reminder, which is recommended.</p> <p>FOFF, energy saving/confidential display mode, in which the instrument will turn off the display of measured value and set value, which can save the instrument power consumption or confidential process temperature. The lower display window displays the current station number, and the alarm symbol will be displayed in case of alarm.</p>	
SPL SP _L	lower limit of SV	The minimum value allowed by the SP.	-9990~ +32000 unit
SPH SP _H	upper limit of SV	The maximum value allowed by the SP.	
SP1 SP ₁	Given point 1	When the parameter Pno=0 or 1, the given value SV=SP1.	SPL~ SPH SPL~ SPH
SP2 SP ₂	Given point 2	When parameter Pno=0 or 1, I2 module is installed at MIO position, and parameter Et=SP1.2 is set, SP1/SP2 can be switched through an external switch. When the switch is off, SV=SP1, and when the switch is on, SV=SP2.	
PASd PR5d	Password	<p>When PASd is equal to 0-255 or AF.D=0, set Loc=808 to enter the complete parameter table.</p> <p>When PASd is equal to 256-9999 and AF.D=1, Loc=PASd must be set to enter the parameter list.</p> <p>Note: Only professional users can set PASd. It is recommended to use a unified password to avoid forgetting.</p>	0~9999
Strt SEr t	Valve rotation stroke time	Strt is used to define the stroke time of valve rotation when the instrument is a position proportional control output; If there is a valve feedback signal, the instrument will automatically select the return difference of the valve control signal according to the Strt setting. The shorter the stroke time, the greater the return difference, and the lower the valve positioning accuracy. When the mode of no valve feedback signal is used or the valve feedback signal generates an over range fault, the instrument will determine the action time of the valve motor according to the stroke time comparison defined by Strt.	10~240s

Nonc nonc	N.O./N.C. selection	<p>A single channel alarm relay can simultaneously output normally open and normally closed, while a dual channel alarm module L3 only has normally open output. However, the normally open output can be defined as normally closed output through the non c parameter. nonc=0, L3 relays installed in AL1, AL2, AU1, and AU2 are all normally open outputs; nonc=15, all instrument alarms are normally closed outputs. When it is necessary to keep some channels open and some channels closed, the nonc value can be calculated according to the following formula.</p> $\text{Non c} = A*1 + B*2 + C*4 + D*8$ <p>A, B, C, and D represent the normally open and normally closed outputs of AL1, AL2, AU1, and AU2, respectively. When the value is 1, it is the normally closed output, while 0, it is the normally open output.</p>	0~15
EFP1 EFP1	Lower limit of current alarm value	<p>The percentage is used by EFP1~3. The CT function (AF2. H=1) needs to be enabled, paired with the I9 module, and the external transformer needs to be converted to AC 0~50mA. Try to match two or more transformers, so that the normal current percentage is around 20%~40%. For example, the normal current is about 15A, and 50mA is optional. This way, EFP3 will display around 30 during normal use, indicating a current of 30%; At this point, set EFP1=20 for load disconnection judgment, and EFP2=50 for actuator short circuit judgment; When a current alarm is generated, the instrument will flash CtAL while AU1 outputs. Setting AF. C=1, the three row display instrument can display the EFP3 current percentage on the third row.</p> <p>Note: SSR output or relay output should be selected, and the output cycle should be greater over 0.2 seconds.</p>	0~100
EFP2 EFP2	Upper limit of current alarm value		0~100
EFP3 EFP3	Current percentage		
EAF EAF	Parameter selection for expanding advanced functions	<p>The EAF parameter is used to extend advanced functions, and its calculation method is as follows:</p> $\text{EAF} = A*1 + C*4 + D*8 + E*16 + F*32$ <p>A=0, automatically selects the refresh speed of the main input based on the setting of CTI control cycle parameters (120mS~960mS; 100~800mS when Fru=60Hz).</p> <p>A=1, standby, the refresh speed of the main input is customized by special VIP users;</p> <p>A=2, the refresh speed of the main input is about 60mS (approximately 50mS when Fru=60Hz);</p> <p>A=3, the refresh speed of the main input is about 120mS (approximately 100mS when Fru=60Hz);</p> <p>C=0, disable automatic switching of two sets of PID parameters based on SV size; C=1, enable automatic switching of two sets of PID parameters based on SV size.</p> <p>D=0, PID parameter switching set value is defined by parameter OEF; If SV>OEF, use the second set of PID parameters, otherwise, use the first set of PID parameters; If D=1, the parameter switching set value is defined by the parameter SPSH;</p>	

<p>EA F EA F</p>	<p>Parameter selection for expanding advanced functions</p>	<p>Note: To avoid output disturbance during switching, the output cycles of the two sets of PIDs should usually be set to be consistent, and the differential time should be consistent too.</p> <p>E=0, AUX slot is in normal use; E=1, AUX slot for transmission output, needs to be paired with AUX.</p> <p>F=0, AUX for transmission output and transmits PV; F=1, AUX for transmitting output and transmits SV.</p> <p>Note: AI-8 * 6 series does not have EAF function</p>	
<p>Prn Prn</p>	<p>Functional parameters for selecting multiple program segments</p>	<p>Prn represents the number of the currently selected program group (0-9); When the Prn value is modified and the instrument is in the STOP status, the instrument will automatically save the previous 50 program segments to FLASH memory and load a new numbered program segment. Even if the number of program segments in the instrument is set to 0, modifying Prn will switch between 10 different sets of given values for SP1 and SP2.</p> <p>Note: FLASH large capacity memory is used to store data. According to the chip manufacturer's manual, the switching write life is 100,000 times, which is different from the instrument's description (including the currently loaded program) that the number of write times exceeds 2 billion. When switching program segments, the system will pause for about 10ms to write to FLASH memory, which will affect some real-time communication and control functions. Therefore, when the instrument is in the STOP status, the command to switch the program is executed.</p> <p>Note: AI-8 * 6 series does not have Prn function</p>	
<p>EP1- EP8 EP 1- EP8</p>	<p>Definition of parameters used on site</p>	<p>One to eight field parameters can be defined, which are commonly used after Loc locking and need to be modified by field operators. If there are no or less than eight field parameters, their values can be set to nonE.</p>	

5. Common Function Description

Note: For a complete description of the parameters involved in the following function introduction, please refer to the complete parameter table.

5.1 SCR Trigger Output Function

5.1.1 Single-phase Phase-shift Trigger Output

Parm.	Setting	Description
OPt	PHR I	SCR single-phase phase-shift trigger output, SCR is 5-500A, if a larger-size SCR will be used, please specify when ordering.

It can realize continuous heating power adjustment by controlling the conduction angle of the SCR (2 unidirectional inverse parallel or 1 bidirectional SCR), and according to the characteristics of the sine wave, the nonlinear correction of the power is carried out to achieve the ideal control effect. The trigger uses self-synchronizing technology, which allows the instrument power and heater power to be different. Phase-shift triggering will bring high-frequency interference to the power grid. It is recommended to add RC resistance-capacitance circuits. When applying, pay attention to whether the anti-interference of other electrical appliances can meet the requirements.

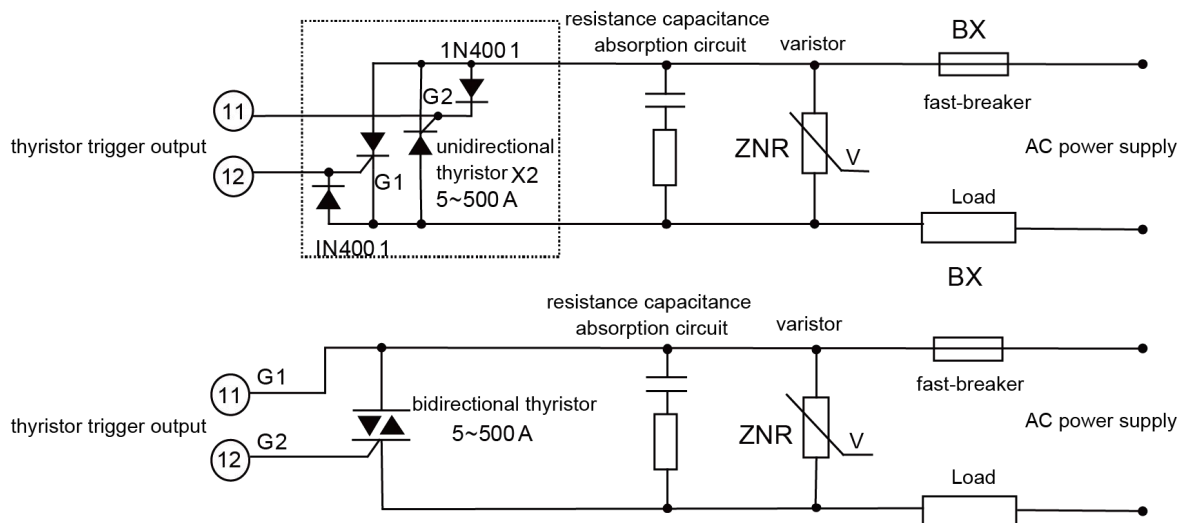

Note 1: Resistor-capacitor absorption and varistor must be added when phase-shift trigger is used to improve possible harmonic interference.

Note 2: It is recommended to use a SCR power module. One power module contains two unidirectional SCRs, as shown by the dotted line in the figure.

Note 3: When using the K60 module, the load power supply is 380VAC; when using the K50 module, the load power supply range is reduced to 200~240VAC.

5.1.2 Single-phase/Three-phase Zero-crossing Trigger Output

Parm.	Setting	Description
OPt OPt	SSr 55r	SCR single-phase/three-phase zero-cross trigger output, SCR is 5-500A, if a larger-size SCR will be used, please specify when ordering.

The output power is adjusted by adjusting the ON-OFF time ratio, and the cycle is usually 0.5-4.0 seconds. Select the appropriate varistor according to the load voltage to protect the SCR, the output wiring of the K1 module is the same as the single-phase phase-shift trigger output, and the three-phase zero-crossing wiring is shown in the following figure:

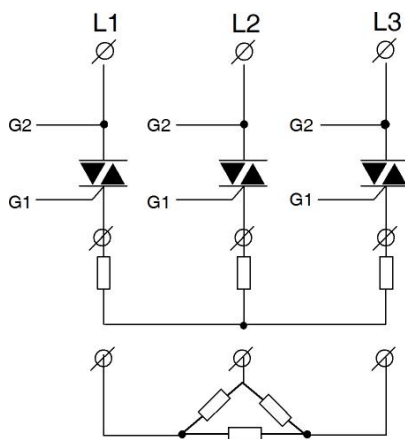

K3 three-phase three-wire star and delta wiring diagram (TRIAC)

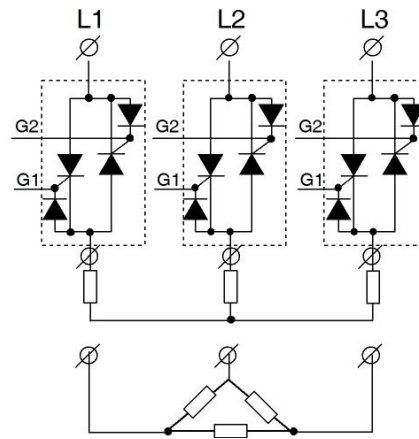

K3 three-phase three-wire fully controlled power module star and delta wiring diagram (single-phase SCR anti-parallel)

5.2. Position Proportional Output Function

5.2.1 Proportional output with feedback position

After setting this output, if OPH is less than 100, the instrument will automatically set the valve position when powered on, that is, it will automatically close the valve when powered on, and the time is the valve stroke time. The OPH parameter can limit the maximum valve opening when the measured value PV is less than the parameter OEF. If the OPH=100 is set, the instrument will automatically set the valve position when the output is 0% and 100%, and will not automatically set the valve position to shorten the startup time when power on.

Parm.	Setting	Description
OPt	nFEd	Position proportional output without valve position feedback signal
Start rt	60	Valve stroke time, the factory default value is 60S, which needs to be modified according to the actual valve stroke time

5.2.2 Proportional output with feedback position

When there is proportional output with feedback position, it is necessary to do valve position auto-tuning. The instrument will automatically close the valve first, and then fully open the valve, then measure the feedback signal to set the valve position and save it. After the valve position self-tuning is completed, the instrument will automatically set the parameter OPt to FE_d, and the valve position signal will be saved in SPSL and SPSH parameters. During normal control, if the feedback signal exceeds 2% of the measuring range, it will be considered that the feedback signal is abnormal, and the control will be automatically carried out in the mode of no valve feedback signal. At the same time, "FE_{rr}" will be displayed on the lower display window to indicate an error. The feedback signal can be 1K resistance (W5 or U5 module is required) or 0~5V/1~5V signal (current 0~20mA/4~20mA can be converted by parallel resistance). It is recommended to use A2, E2 and other instrument panels with light column indication, which can indicate the valve opening rather than the output value calculated by the instrument.

Note: When setting the position proportional output with feedback, please do not set the measurement input signal to 0-1V and above voltage signal or set the external given function.

Parm.	Setting	Description
OPt OPt	FE _d /FEAt FE _d / FEAt	After other parameters are set and wiring is completed, set the instrument to FEAt to open the valve position auto-tuning
SPSL SPSL	0 0	It is the lower limit of the valve position, which is automatically written after the valve position is set
SPSH SPSH	1000 1000	It is the upper limit of the valve position, which is automatically written after the valve position is set

5.3 External Event Input Function

If I2 module is installed on MIO socket (or set bAud=1, and I2/I5 module is installed on COMM socket), a switch can be connected externally, and control functions can be executed through on-off of the switch to realize operation stop switching, dual set value switching, manual/automatic switching, etc.

Parm.	Setting	Description
Et Et	RuSt, SP1.2等 RuSt SP1.2 etc.	Set different options to realize the function switching of the instrument controlled by external switches

5.4 Quick Tuning of AAT Function

Traditional periodic oscillation auto-tuning requires 2 cycles to set PID parameters, which requires a long debugging time. The fast tuning function is that when the instrument is powered on and in the full power heating output state, the PID parameters can be calculated by analyzing the temperature rise curve, and the PID parameters can be set in advance without periodic oscillation. In most cases, accurate control can be achieved by the first heating, greatly shortening the commissioning time. If the AAT has not been completed automatically, the instrument will exit the full

power output state, then the AAT will fail, the self-tuning will be terminated, and the PID parameters will not be modified.

Parm.	Setting	Description
At AŁ	AAŁ AAŁ	The quick setting function can be started after the instrument is powered on for operation

5.5 External Given Function

External setting refers to changing the setting value of the instrument through external analog signals, which can realize the functions of proportional adjustment, cascade adjustment, manual operator, etc. The external given signal is fixed as 0-5/1-5V voltage signal. When the external given function is valid, the internal given value does not work. When the external given signal is disconnected, the internal given value will be switched automatically.

Note: When the external given function is set as valid, please do not set the measurement input signal as 0-1V or above voltage signal or set the feedback position proportional output.

Parm.	Setting	Description
AF2 AŁŁ	1 or 3 1或3	It is used to set whether the external given function is effective, and set the external given signal as 0-5/1-5V
SPSL SPSL	0 0	Lower limit of external given signal range
SPSH SPSH	1000 1000	Upper limit of external given signal range

5.6 Soft-starting Function

This function can be enabled when the equipment needs to gradually increase output according to time when it is powered on or started up for operation. If the measured value PV is less than OEF when the instrument is powered on or stopped, the maximum allowable output of the main output OUTP after operation will rise to the output percentage set by OPH after the set time. If the measured value is greater than OEF when powered on or stopped, the rising time of the output is limited to 5 seconds.

Parm.	Setting	Description
OPrt OPŁ	0~3600s 0 or 3600s	The soft start time is 0 by default. To reduce the impact current of inductive load, Ctl=0.5 s and OPrt=5 s can be set

5.7 Heating and Cooling Dual output function

When the OPL parameter is set to - 1~ 110% and the control mode Ctrl is set to APId/nPid, the instrument will become a two-way output system, with two opposite PID control outputs, the main output OUTP and the auxiliary output AUX. The main output uses P, I, d, ctl control parameters, and the auxiliary output uses P2, I2, d2, ctl2 control parameters. When the instrument is a two-way output, OPL is used to reflect the maximum cold output limit. When OPL=- 100%, there is no limit on cold output, -110% can make the maximum range of current output (4~20mA) exceed

10% or more, which is suitable for special occasions; When SSR or relay outputs, the maximum cold output limit shall not be greater than 100%.

Parm.	Setting	Description
OPt OPt	SSr etc SSr etc.	Set signal type of the main output
Aut Aut	SSr etc SSr etc.	Set signal type of auxiliary output
OPL OPL	-1~-110% - 1 ~ - 1 1 0	Set as the maximum output percentage of auxiliary output terminal
OPH OPH	0~110% 0 ~ 1 1 0	Set as the maximum output percentage of the main output terminal

5.8 Overrange Output Definition Function

During the operation of the instrument, when the input sensor signal exceeds the range or "orAL" alarm occurs abnormally, the instrument will automatically close the output. In some special occasions, dangerous situations may occur, for example, the control instrument of the cooling water valve in the machine room closes its output due to abnormal measurement signals, which may cause overheating or burning of the equipment. When the input signal of the instrument "orAL" alarms, after the over range output function is set, the instrument can work according to the preset output percentage signal or automatically set the appropriate output to avoid the above situations

Parm.	Setting	Description
AF2 AF2	16or48 16 or 48	Set whether to enable the over range output function, and set the Ero output in manual or automatic mode
Ero Ero	0 0	Set the output of the overrange, manually set in the manual mode, and automatically set in the automatic mode

5.9 Limiting function of Temperature Rise/Fall Rate

When the equipment does not allow rapid heating or cooling due to material and other factors, the function of setting the temperature rise/drop rate limit is effective. After the instrument changes the set value or the program starts (platform mode), if the measured value is not equal to the set value, it will rise/fall to the set value or program segment value according to the set rise/fall rate limit value. The PRG light will flash when the rise/fall rate is limited. If the system has no refrigeration output, when the natural cooling rate is lower than SP_{rL}, the instrument cannot guarantee the cooling slope, thus it will be cooled at the natural cooling rate.

Parm.	Setting	Description
SPr SPr	0~3200 0-3200	Set the temperature rise rate limit value, in °C/min
SPrL SPrL	0~3200 0-3200	Set the limit value of cooling rate, in °C/min

5.10 Power-on Operation Mode Selection Function

After the equipment is powered on or powered on again due to accidental power failure, the instrument can select the power on operation mode to change the working state of the instrument as required.

Parm.	Setting	Description
PonP	Cont/StoP etc.	Select the operating state of the instrument after power-on again
P _{on} P	Cont/StoP etc.	

5.11 Instrument Power Frequency and Temperature Unit Selection Function

The instrument can select the working power frequency, so that the input signal has the maximum anti-interference ability under the power frequency. The display of Celsius and Fahrenheit temperature values can be selected.

Parm.	Setting	Description
Fru	50C\50F\60C\60F	Select operating power frequency and temperature unit
F _{ru}	50C\50F\60C\60F	

5.12 Exempt from Alarm Function at Power-on

The instrument often leads to some unnecessary alarms after it is just powered on, for example, when the electric furnace temperature is controlled (heating control), and it is just powered on, its actual temperature is far lower than the given temperature. At this time, if the user sets the lower limit alarm or the lower limit deviation alarm, the instrument will meet the alarm conditions as soon as it is powered on, but in fact, the control system may not have problems. On the contrary, under the refrigeration control (positive action control), the instrument may have an upper limit alarm or deviation upper limit alarm just after being powered on. Therefore, AI instruments provide power on alarm exemption settings. Even if the instrument meets the corresponding alarm conditions after power on, it will not alarm immediately. After the alarm conditions are canceled, if the conditions that meet the alarm requirements occur again, the corresponding alarm will be generated.

Parm.	Setting	Description
Act	rEbA or drbA	Set rEbA as the power-on exemption lower limit alarm; set drbA as power-on exemption upper limit alarm
R _{ct}	rEbA or drbA	

5.13 Communication Function

AI series instruments can be installed with S or S4 and other communication modules at the COMM position, and can be connected with computers to realize various operations and functions of the instrument. For the computer without RS485 interface, one RS232C/RS485 converter or USB/RS485 converter can be added. Each communication port can directly connect 1-60 instruments. With RS485 repeater, up to 80 instruments can be connected. One computer can support multiple communication ports. Please note that each instrument shall be set with a different address. When there are more than one instrument, two or more computers can be used, and a local network can be formed between the computers. The manufacturer can provide AIDCS application software, which can run under the Chinese WINDOWS operating system, realize centralized monitoring and management of 1~200 AI series instruments of various models, and automatically record and print measurement data. If users want to develop their own configuration software, they can ask the instrument seller for free when obtaining the communication protocol. A variety of configuration software can support AI instrument communication.

Parm.	Setting	Description
AFC RFCL	0~12 0~12	Set communication mode, select MODBUS-RTU or AIBUS, etc
Addr Raddr	0~80 0~80	Set communication address
bAud hRaud	0~28.8K 0~28000	Set communication baud rate

5.14 Temperature Transmitter/Programmed Generator

In addition to the conventional APID/nPID or ON-OFF position adjustment, the instrument can also directly output the measured value (PV) or the given value (SV) from the OUP or COMM terminal. When the output is defined as current output, AI-8 can be used as a temperature transmitter, and when the program function is enabled, it can be used as a program given generator. The current output accuracy is 0.3% FS of the corresponding display value.

5.14.1 The OUP terminal transmitting output

Parm.	Setting	Description
Ctrl CTRL	POP or SOP POP or SOP	Set the transmitted PV value or transmitted SV value
SCL SCL	0 0	Set the lower limit value of input signal and that of transmission
SCH SCH	1000 1000	Set the upper limit value of input signal and that of transmission
OPt OPt	0-20/4-20 0-20 / 4-20	Set transmission signal type

For example, the instrument is required to have the K index thermocouple transmitting function, the temperature range is 0~400 °C, and the output is 4~20mA. The parameters are set as follows: InP=0, SCL=0.0, SCH=400.0, OPt=4-20, OPL=0, OPH=100. For the defined transmitter, when the temperature is less than or equal to 0 °C, the output of X3 or X5 linear current module installed at the OUP position is 4mA; when the temperature is greater than or equal to 400 °C, the output is 20mA; when the temperature is between 0 °C and 400 °C, the output changes continuously between 4 and 20mA.

5.14.2 Transmit output at the COMM terminal (Note: only one of the functions of COMM position transmission, communication and event input can be selected)

Parm.	Setting	Description
bAud bRud	3 or 4 or 8 or 12 3 or 4 or 8 or 12	Set PV value or SV value and 0-20 or 4-20mA
SCL SCL	0 0	Set the lower limit value of input signal and that of transmission
SCH SCH	1000 1000	Set the upper limit value of input signal and that of transmission

5.15 Fine Control

Fine control refers to that the PID operation resolution is 10 times higher than the display resolution. For example, the instrument temperature signal is displayed as 1 °C, but the internal PID is still calculated and controlled according to the resolution of 0.1 °C, which can achieve a much higher control accuracy than the display resolution. In previous versions of AI series instruments, only the temperature signal adopts the fine control mode; When the new version is used for linear input, as long as the displayed value range is less than 3000 words (most industrial applications are no more than 3000 words), fine mode is used by default for control to obtain higher control accuracy and more stable output. When the displayed value range is greater than 3000 words, high resolution mode can be set.

Parm.	Setting	Description
AF RF	AF.F=0 or1 0 or1	If F is selected as 0 in AF parameter, it is fine control mode; Select 1 as the high resolution display mode

5.16 Custom Input Specifications

When the parameter InP=10 is set, the instrument input specification is a user-defined input type, and non-linear tables can be edited. Setting method: Set Loc parameter to 3698 to enter the table setting state. The parameter A 00 definition table is used for: 0 for input nonlinear measurement or multi segment linear correction of input signal, 1 for nonlinear power control of high temperature furnace; Parameters include A01~A04 and d00~d59 (the values of A02~A04 and d00~d59 have decimal places. If dPt is set to 0.0, the values of A02~d59 should be divided by 10), respectively set as follows:

A 00: 0

A 01: Define the input type, whose values are defined as follows:

$$A\ 01=A\times 1+E\times 16+G\times 64$$

A indicates input signal range: 0, 0~20mV (0-80 Ω); 1, 0~60mV (0-240 Ω); 2, 0~100mV (0-400 Ω); 4, 0~5V; 10, 0~20mA(I44 module is installed at MIO position).

E indicates input signal display:

0, indicating that the table output value needs to be calibrated again by the SCH/SCL parameter when the linear input signal is used. 1, indicating that the table output value is the display value.

G indicates the type of input signal (determine whether the input signal is temperature type or non temperature

type):

0, thermocouple; 1. Thermal resistance; 2. Linear voltage (current); 3. Linear resistance.

For example, if the signal is 1-5V voltage input and not temperature type, set $A01=4 \times 1+0 \times 16+2 \times 64=132$

A 02: Define the lower limit of the input signal, equal to the lower limit of the signal $\times K/\text{range}$, e.g. 1-5V signal input, $A02=1 \times 25000/5=5000$ can be set.

K is the signal coefficient, where the coefficient is 20000 when A01. A is 0, 25000 when A01. A is 2, 4 and 10, and 30000 when A01. A is 1.

A 03: Define the input signal range, equal to the signal range $\times K/\text{range}$, for example, in 1-5V input, if the range is 5-1V=4V, $A03=4 \times 25000/5=20000$ should be set.

A 04: Define the table spacing of input signals, $A04=A03/\text{number of curve segments}$. If there is only one segment, A04 is equal to A03; If it is divided into two sections, $A04=A03/2$.

d 00: represents the starting point value of the curve table, which corresponds to the output value when the input signal is A02.

d 01: represents the value of the first segment of the curve table, which corresponds to the output value when the input signal is $A02+A04$, for example, it can be set as 20000 in 1-5V input (full scale).

d 02-d59: indicates the values of the 2nd to 59th segments of the curve table. All applications can correct very complex curves, such as square root, logarithmic and exponential curves.

5.17 Multi-segment Linear Correction Function of Input Signal

When the input specification InP is set to plus 64, the instrument has the input multi segment linear correction function. Setting method: Set Loc parameter to 3698 to enter the table setting state (if Loc=808, set Loc to 0 first, exit the parameter setting state, and then enter the parameter state again to set Loc to 3698). The settings are as follows:

A00: 0;

A01: Input signal and display setting:

$A01=A \times 1+E \times 16+G \times 64$

A indicates signal range: A=0, 0~20mV (0-80 Ω); A=1, 0~60mV (0-240 Ω); A=2, 0~100mV (0-400 Ω).

E indicates signal display: E=0, no effect; E=1, the values set in the table d00~d59 are the displayed values.

G indicates signal type: G=0, thermocouple; G=1, thermal resistance.

For example, if the signal is thermocouple input and temperature type, set $A01=2 \times 1+1 \times 16+0 \times 64=18$

A02: Starting temperature

A03: measuring range=highest value measured - A02

A04: Temperature interval of each section= $A03/\text{number of sections}$

D00~d59: temperature setting value of each section

For example, the input range of K thermocouple is 0 to 300 degrees, one decimal place, correction every 100 degrees. Then set parameters A00=0, A01=18, A02=0.0, A03=300.0, A04=100.0, d00=0.0, d01=100.0, d02=200.0, d03=300.0. Just set the corresponding temperature point slightly higher or lower than the value displayed on the instrument, for example, the instrument shows 200.0 degrees, and the calibration device measures 202.0, then change d02=200.0 to d02=202.0.

Note: The corrected value is the value of each point, and the point-to-point transition is automatic and linear. When this function is enabled, the instrument can only be displayed within the temperature range set by the table. When the actual temperature exceeds the table range, the instrument will display the orAL overrun alarm.

5.18 Nonlinear Power Control Function of High Temperature Furnace

For high-temperature furnaces with non-linear load, the resistance will change dramatically with the temperature change. Take the silicon-molybdenum bar furnace as an example, its room temperature is about 6% when the resistance is only 1600 degrees. If the output power of the instrument is not limited and transformed, it will lead to two problems. First, when the instrument starts at low temperature, the current of the electric furnace is too large and exceeds the maximum allowable load of the power grid, thyristor and transformer, which causes damage to thyristor, electric furnace and transformer or even causes power grid tripping. In addition, when the instrument has the same output, the power of the electric furnace in the low temperature zone and the high temperature zone will differ by more than 10 times at most, which means that the proportional band P in the PID parameter needs to change by more than 10 times at different temperatures to enable accurate temperature control in the low temperature and high temperature zones. However, the method of limiting parameter OPH can only limit the output power and cannot achieve proportional band transformation. If accurate temperature control is required in high and low temperature areas, multiple sets of PIDs need to be set, which is not only complex to use, but also ineffective. The user-defined output limit transformation function simultaneously solves the function of limiting output and transforming the proportional band P. This function limits and transforms the instrument output according to the measured temperature. It not only limits the power in the low temperature zone, but also automatically corrects the parameters of the proportional band at different temperatures. The power limit and the change of the proportional band are both continuous broken line mode, which is better than the grouping mode. The power limit only reduces the actual output of the instrument proportionally, while the display range of the instrument output is still 0~100%. For example, when it is used for silicon molybdenum bar furnace, it can be set as follows (customers can also modify the data according to their own needs):

A00=1, a01=1050, A02=100.0A03=1500A04=750.0, d00=120.0d01=1100, d02=2000

When parameter A00=1 and A01=1050 are set, the instrument enables the user-defined output limit transformation function. A02 represents the initial temperature of the output limit, A03 represents the temperature range of the output limit, and A04 represents the segment length of the nonlinear data temperature segment. In this example, 1500/750.0=2 represents two segments. The more segments, the more complex and refined the curve can be. D00 represents the maximum output power when it is lower than A02, and its unit is $100\% \times (1/2000)$, d00=120.0 means 6%, d01 means 55%, and d02 means 100%. The meaning of this curve is that when the temperature is below 100 °C, the output limit is 6%; when the temperature is between 100 °C and 850 °C, the power limit is 6% and smoothly transits to 55%; when the temperature is between 850 °C and 1600 °C, the power limit is 55% and 100%; when the temperature is above 1600 °C, the power limit is not limited to 100%.

Note: The range of d value is 0~59, which is equivalent to the maximum power limit of 60 segments. This function cannot be used with the input multi segment linear correction function at the same time. If it is used at the same time, special specification input is required. Please contact the seller to negotiate the solidification into the instrument, but there may be a one-time additional payment.

6. Program Control (Pno≥1)

The AI-8 * 8 program type instrument is used in situations where it is necessary to automatically change the set value for control according to a certain time rule. It not only has the function of 50 segments programming, which can set the rise and fall slope of any given value, but also has programmable/operable commands such as jump, run, pause and stop, which can modify the program during program control operation; in addition, it has power failure processing mode, measured value startup function and preparation function as well, which makes program execution more efficient and perfect.

6.1 Function and Concept

Program segment: the segment number can range from 1 to 50. The current segment (StEP) represents the segment currently being executed.

Setting time: refers to the total running time set in the program segment, in minutes or hours, with effective values ranging from 0.1 to 3200.

Running time: refers to the running time of the previous period. When the running time reaches the set period, the program automatically moves to the next period.

Jump: the program segment can be programmed to automatically jump to any segment to achieve loop control. Jumping can also be achieved by modifying the value of StEP.

Run (run/HoLd): When the program is in the running state, the time is timed, and the given value changes according to the prearranged program curve. When the running state is maintained (paused), the time stops timing and the given value remains unchanged. The pause operation (HoLd) can be programmed in the program segment.

Stop: The execution of stop operation will stop the program running. At this time, the running time is cleared and the timing is stopped, and the control output is stopped. If the operation is executed in the stopped state, the instrument will start the operation program from the segment number set by StEP. The function of automatic stop can be programmed into the program segment, and the StEP value of the running segment number can be set at the same time. Besides, Manually stop is enabled at any time (StEP is set to 1 after execution, but users can modify it again). If the program segment number has finished running the last segment defined in the Pno parameter, it will stop automatically.

Power failure/startup event: it refers to the power on of the instrument or the accidental power failure during operation. A variety of different treatment schemes can be selected by setting PonP parameters.

Preparation (rdy) function: If the measured value is different from the given value (if the measured value startup function is allowed, the system first uses the measured value startup function for processing; if the measured value startup function can work effectively, the standby function does not need to work, and only those that do not meet the processing conditions of the measured value startup function can be processed with the preparation function) when the running program is started and the program needs to be continued after the unexpected power outage/startup, And when the difference is greater than the deviation alarm value (HdAL and LdAL), the instrument will not immediately give a positive (or negative) deviation alarm, but first adjust the measured value to a value whose error is less than the deviation alarm value. At this time, the program also pauses timing, and does not output the deviation alarm signal. The program will not start until the positive and negative deviations meet the requirements. The preparation function is also useful for setting the segment where the rise/fall time cannot be predicted. To allow or cancel the preparation function, the instrument is allowed to set it in the PAF parameters. The preparation function can ensure the integrity of the whole program curve, but the preparation time may increase. Both the preparation function and the measured value startup function are used to solve the uncertainty of the program operation caused by the inconsistency between the measured

value and the given value during startup and operation, so as to obtain the program operation results that are efficient, complete and meet the user's requirements.

Start function of measured value: When starting the running program and continuing the running program after an unexpected power outage/startup, the actual measured value of the instrument is often different from the set value calculated by the program, and this difference is sometimes unexpected and unpredictable. For example, for a temperature rise section program, the instrument is set to rise from 25 °C to 625 °C after 600 minutes, with a temperature rise of 1 °C per minute. Assuming that when the program is started from the starting position of this section, if the measured value is just 25 °C, the program can be successfully executed as originally planned. The measured value startup function can be made consistent by the instrument by automatically adjusting the running time. For example, in the above example, if the measured temperature is 100 °C when starting the operation, the instrument will automatically set the running time to 75 minutes, so that the program will start running directly from the position of 100 °C.

Curve fitting: it is a control technology adopted by AI-8 instrument. Because the control object usually has the characteristics of time lag, the instrument automatically smooths the linear rise, drop and constant temperature curves at the break point. The degree of smoothness is related to the system's lag time t ($t = \text{differential time } d + \text{control cycle } Ctl$). The greater t is, the greater the degree of smoothness is, and vice versa. The smaller the lag time (such as thermal inertia) of the control object, the better the program control effect. Processing program curves by curve fitting can avoid overshoot.

Note: The characteristic of curve fitting causes the program control to produce a fixed negative deviation when the linear program heats up and a fixed positive deviation when the linear program heats down. The value of the deviation is proportional to the lag time (t) and the rate of temperature rise (fall). This is a normal phenomenon.

6.2 Programming

6.2.1 Slope mode

When parameter PAF.B=0 is set, The program is arranged in the format of temperature~time~temperature, which is defined as: set the temperature from the current segment, and reach the next temperature after the time set in this segment. The unit of temperature setting value is the same as the measured value PV, while the unit of time value can be selected as minute or hour. In slope mode, if the last segment of program defined by Pno is not a stop command or jump command (the time setting in the following text can be edited), it means that it will end automatically after holding this segment of time at this temperature. The following example is a five segment program example including linear temperature rise, constant temperature, linear temperature drop, jump cycle, preparation and pause.

1st segment SP 1=100.0 t 1=30.0; Starting from 100 °C, the temperature rises linearly to SP 2, with a temperature rise time of 30 minutes and a temperature rise slope of 10 °C/minute

2nd segment SP 2=400.0 t 2=60.0; Run at 400 °C for 60 minutes

3rd segment SP 3=400.0 t 3=120.0; Cool down to SP 4, the cooling time is 120 minutes, and the cooling slope is 2 °C/minute

4th segment SP 4=160.0 t 4=0.0; When the temperature drops to 160 °C, it will enter the pause state, and the next section can continue after *run* is executed

5th segment SP 5=160.0 t 5=- 1.0; Skip to the first paragraph for execution and start running from the beginning of the cycle.

In this example, after the fifth segment jumps to the first segment, because its temperature is 160 °C, while C 01 is 100 °C, which is not equal, and the fifth segment is also a jump segment, assuming that the upper limit of deviation alarm

value is set to 5 °C, the program will first enter the preparation state after the fifth segment jumps to the first segment, that is, that is, control the temperature to less than the upper limit of deviation alarm value first, i.e. 105 °C, and then conduct the temperature rise program in the first section. The temperature control procedure is shown in the figure below:

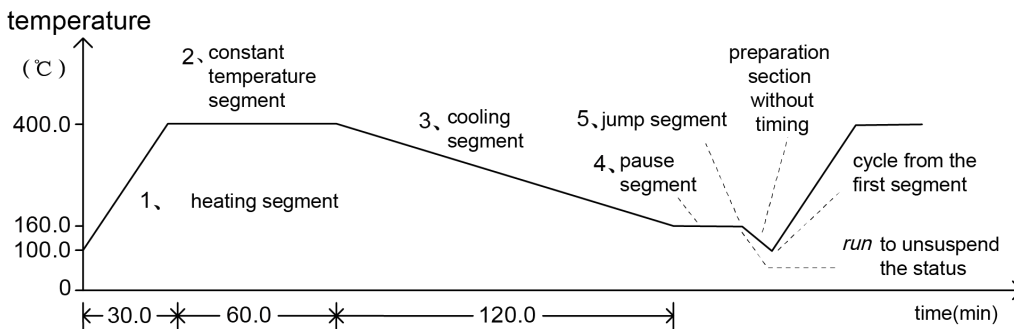

The advantage of using temperature-time programming method is that the slope setting range of temperature rise and drop is very wide. The heating and constant temperature sections have a unified setting format, which is convenient for learning. Besides, it is more flexible to set curve, and possible to set a continuous heating section (for example, use a heating section with different slopes to approximate functional heating), or a continuous constant temperature section as well.

6.2.2 Platform Mode

When parameter PAF.B=1 is set, the platform mode can be selected, which is suitable for applications that do not need to set the temperature rise slope independently and do not need to set the temperature drop slope. It can simplify programming and make more effective use of the number of segments. Each segment of the program means the temperature~the constant temperature time of the temperature. A temperature rise rate limit can also be defined with the SPR parameter between segments. If SPR is set to 0, it means full speed temperature rise. Since the temperature rise time cannot be determined and will occupy the holding time, rdy can be set to be effective to ensure the correct constant temperature time.

1st segment SP 1=300.0 t 1=30.0; temperature at 300 °C for 30 minutes

2nd segment SP 2=500.0 t 2=45.0; temperature at 500 °C for 45 minutes

3rd segment SP 3=100.0 t 3=60.0; temperature at 100 °C for 60 minutes

4th SP 4=160.0 t 4=-121.0; the program enters the stop state.

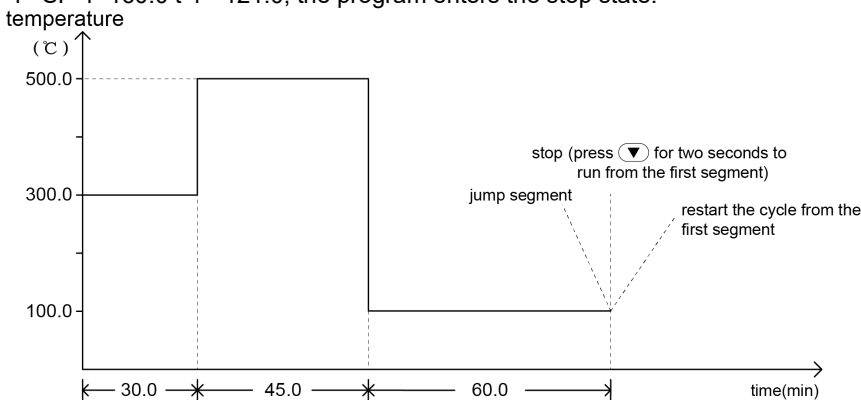

The platform mode only needs to set the temperature and constant temperature time. It does not need to set the temperature rise process. As shown in the figure above, the platform mode can be set to skip, stop, cycle, etc. The above settings are actually listed as stop.

6.2.3 Set Program Given Value and Time

Each program section includes a given value and time. The range of values that can be set for a given value is limited by SPL and SPH. It is -999~+3200 °C, representing the temperature value (°C) to be controlled or the linear definition unit. Time, in addition to the running time, has special control functions, with the following meanings:

t-XX = 0.1~3200 (min) indicates the time value set in the XX segment (Note: the time unit can also be changed to hour with PAF parameter).

t-XX = 0.0 The instrument enters HoLd in the XX segment, where the program stops running and stops timing.

t-XX = -121.0, the program executes the Stop operation and enters the stop state.

t-XX = -0.1~-122.0 A negative time value indicates a jump+event output command. The integer part -1~-120 represents the jump segment, but it is invalid when the number of segments exceeds the number defined by Pno. The integer is 0 (the decimal is not 0), which means that the next segment is run. The decimal position is the event output programming, which can be programmed to make AL1 and AL2 act during the program running. -XXX.0 means that it does not affect the program event state, but only jumps. Note that if the alarm output definition AOP also defines that the alarm is output by AL1 or AL2, the program event or alarm can cause AL1 or AL2 to act. The meaning of -XXX.1~-XXX.4 is as follows:

-XXX.1, AL1 acts and AL2 is released;

-XXX.2, AL1 is released and AL2 acts;

-XXX.3, Both AL1 and AL2 act;

-XXX.4, Both AL1 and AL2 are released;

For example, if t -5=-1.1 is set, it means that when the fifth segment of program is run, AL1 acts, and AL2 releases and jumps to the first segment.

For another example, if t -6=-0.3 is set, it means that when the sixth segment of program is run, AL1 and AL2 act and continue running the next segment of program (the seventh segment).

Note: In addition to the jump segment encountered during the operation or power on, the jump operation can be continued. If the jump segment jumps to the jump segment during the program operation, the program will automatically suspend execution (that is, the instrument will automatically insert the pause operation in two consecutive jumps), and external operation is required to remove the pause status. Please note that if the jump segment jumps to itself (for example, t -6=-6), it will not be able to release the suspended state, because such a segment can be said to be meaningless.







6.2.4 The Programming Method of Running Multiple Curves

The programming method of AI-8x8 is advanced and flexible, and the newly added Prn is used to select numbers (0-9) for the current program group; When the Prn value is modified and the instrument is in the STOP status, the instrument will automatically save the previous 50 program segments to FLASH memory and load a new numbered program segment. Even if the number of program segments in the instrument is set to 0, modifying Prn will switch between 10 different sets of given values for SP1 and SP2.

7. Display/Alarm Symbols and FAQs

7.1 Display/Alarm Symbols

After the instrument is powered on, it enters the basic display state. At this time, the upper and lower display windows of the instrument display the measured value (PV) and the set value (SV) respectively. The SV display window can also alternately display symbols or display symbols to indicate the status, as shown in the following table:



Parm.	Description	Solution
At At	Indicates that the meter is in auto-tuning state	Wait for the end of the tuning, or manually change the At parameter to OFF
AAAt AAAt	Indicates that the instrument is in the fast self-tuning state	Wait for the end of the tuning, or manually change the At parameter to OFF
StoP StoP	Indicates that the instrument is stopped	Press  for two seconds to run the instrument, if it fails to run, please check whether there are functions such as communication and event input that restrict the running operation.
Run Run	Indicates that the instrument is running	This symbol is displayed once when the run operation is successful and does not need to be handled
HoLd HoLd	Indicates that the instrument program function is suspended	Press  for two seconds to run the instrument. If it fails to run, please check whether there are functions such as communication and program segment settings that restrict the running operation.
Rdy Rdy	Indicates that the instrument program function is in a ready state	After waiting for the measurement signal to meet the setting requirements, it will automatically continue to run the program, or modify the PAF parameters to cancel this function
A 50 A 50	Indicates that the instrument is in automatic output state, and the number represents the output percentage	Click  to switch to the SV value display state or click  to switch to the manual output state
M 50 M 50	Indicates that the instrument is in the manual output state, and the number represents the output percentage	At this time, the MAN light on the panel is on, click  to switch to the automatic output state, and click  and  to modify the output percentage
orAL orAL	Indicates that the input measurement signal is out of range	Check whether the input specifications and parameters are set correctly, check whether the input wiring is correct, and check whether the input signal is normal
HIAL HIAL	Indicates that an upper limit alarm has occurred	When the measured value PV is less than the HIAL-AHYS value, the alarm will be automatically canceled, or modify the HIAL to 32000 to cancel the alarm

LoAL LoRL	Indicates that a lower limit alarm has occurred	When the measured value PV is greater than LoAL+AHYS, the alarm will be canceled automatically, or modify LoAL to -9990 to cancel the alarm
HdAL HdRL	Indicates that a deviation upper limit alarm has occurred	When the deviation of PV and SV of the measured value is less than HdAL-AHYS, the alarm will be canceled, or modify HdAL to 32000 to cancel the alarm
LdAL LdRL	Indicates that a deviation lower limit alarm has occurred	When the deviation of PV and SV of the measured value is greater than LdAL+AHYS, the alarm will be canceled, or modify LdAL to -9990 to cancel the alarm
FErr FErr	Indicates that the valve feedback or external given signal is over-range	Check whether the valve feedback signal and wiring are normal
FErr EErr	Indicates that an error is detected within the system, such as parameter loss, etc.	Need to return to the factory for repair
CtAL CtRL	current alarm warning	When a current upper or lower limit alarm is generated after pairing with the I9 module, please check the load circuit. Set EFP1 and EFP2 to 0 to cancel this function



Note: If necessary, turn off the character flashing function during upper, lower limit and deviation alarms to avoid excessive flashing (set the ADIS parameter to oFF).

7.2 FAQs

7.2.1 How to self-tune?

When the measured value PV is room temperature, set the set value SV to about 60% of the common temperature (for signals such as pressure or flow, it can be directly set to the common set value), then press  and hold it for two seconds to call up the At parameter, change the parameter value from OFF to ON and click  to start auto-tuning. It can work normally after the auto-tuning At symbol does not flash automatically.

7.2.2 How to enter the internal parameter table?

Press  and hold it for two seconds to enter the parameter table, then short press  to find the next parameter. If the complete parameters are locked, find the password lock parameter Loc, and set it (the default is 808, if it need to be modified, please set the correct password), and then short press  to see all the parameters.



7.2.3 How to judge whether the instrument has output?

First, check whether the OP1 indicator light on the instrument panel is on. If it is not on, please confirm whether the instrument is running, and then check whether the parameters of the instrument are set correctly; if it is on, it means that the output state of the instrument is normal. At this time, the multi-meter can be used to detect whether the output terminal signal of the instrument is normal. If the output signal is normal but the back-end actuator does not work. It is necessary to check other equipment or line faults along the output line. If there is no output signal, it can be judged that the instrument output module is abnormal.

7.2.4 Instrument panel flashing orAL?

This means that the instrument is not detecting an input signal. First, check whether the sensor model corresponds to the input specification parameter Inp, and then check whether the wiring of the instrument input terminal is correct. If there is no problem, regardless of whether the incoming signal from the measuring sensor is correct, the sensor may be damaged.

7.2.5 How to enter the program segment settings?

After the instrument is powered on, click  on the initial display interface to enter the program segment menu, and then click  to display the next data. Each program is arranged in the order of "given value-time-given value". The program segment setting is described in detail in the program control chapter of the manual.

7.2.6 How to set alarm parameters?

First, set the alarm parameter to the required value (for example: if the upper limit alarm is set to be 200 degrees, change the HIAL parameter to 200), then enter the internal parameters to find the AOP parameter to define the alarm signal output terminal (for example: if the upper limit alarm needs to be output from AL1, set the AOP single digit to 1. For the specific definition, please refer to the introduction of AOP parameters in the manual).



7.2.7 How to set bidirectional output for heating and cooling?

Enter the internal parameter table to find the OPL parameter (output lower limit), change the OPL to -1%~-110%, the instrument becomes a bidirectional PID output system, the main output OUTP is used for heating control, and the auxiliary output AUX is used for refrigeration control.

7.2.8 How to set the external given function?

Enter the instrument's internal parameter list to find the AF2 parameter and set it to 1 (enable the external given function), then set the external given scale lower limit parameter SPSL and the external given scale upper limit parameter SPSH parameter, making these two parameters correspond to the given value range. The external given signal input terminals are 17+, 18- (0-5V/1-5V DC signal). After connecting the wires, the external given function can be used normally.

7.2.9 How to switch manual/auto output?

Click  once on the initial interface of the instrument, the SV window of the instrument will switch from the set value to the output value state, then click  to make the instrument switch between automatic and manual without disturbance, A is automatic state, M is manual state. If it cannot be switched, please make sure that the A-M parameter is MAn or Auto.



Keep an eye on public
accounts for technical
support