



# AI-702M/704M/706M

## Multi Channel Inspection Display Instrument

(V9.0)





[www.yudian.com](http://www.yudian.com)

Technical Support Hotline : 400 888 2776

All Rights Reserved©1994-2022



Scan the code to view  
the video tutorial

S176-00

## CONTENT

<b>1. Summary</b> .....	<b>2</b>
<b>2. Ordering Code Definition</b> .....	<b>5</b>
2.1 Selection of Panel Mounted Instrument .....	5
2.2 Selection of D71 Rail Mounted Instrument .....	8
<b>3. Technical Specification</b> .....	<b>12</b>
<b>4. Wiring</b> .....	<b>15</b>
<b>5. Display and Operation</b> .....	<b>18</b>
5.1 Description of Panel Mounted Instrument Panel .....	18
5.2 Operating Instructions .....	19
5.3 Rail Mounted Instrument .....	21
5.4 On Measuring Humidity with Wet and Dry Bulb Method .....	23
<b>6. Parameters</b> .....	<b>24</b>
<b>7. FAQs</b> .....	<b>40</b>
7.1 How to enter the parameter list? .....	40
7.2 Common faults .....	40
7.3 How to set alarm parameters? .....	40

# 1. Summary

AI-702M, AI-704M and AI-706M instrument adopts modular technology to measure 1~2, 1~4 and 1~6 thermocouples, thermal resistance, voltage, current and other signals together with various input modules; it also has the functions of input digital correction and digital filter. In addition, its channels can have different input specifications, and can support up to 7 programmable alarms and 2 transmission and output. Apart from the above, it is suitable for analog data collection module or temperature transmitter in DCS computer monitoring system or PLC control system, which provides analog data collection with rich input specifications, high precision, high stability, intelligently programmed high performance-to-price ratio as well as a switch input or output interface for the upper computer, on the other hand, the upper computer can perform on-off operations through it, such as controlling the start and stop of the motor. This instrument has the characteristics of 100-240VAC range input switch power supply or 24VDC power supply and a variety of installation sizes, has passed the ISO 9001 quality certification and European CE product certification, and has high reliability and meets the EMC electromagnetic compatibility standard as well. Its power supply and all I/O terminals have passed the group pulse anti-jamming test of 6KV, and can work reliably in strong interference environment. The main functions of the instrument are as follows:

- A maximum of six programmable measurement input circuits (AI-706M) can be supported. With different input modules, six thermocouples, thermoresistors, voltage or current signals can be input. Channel numbers can be defined when measuring more than 6 channels, such as CH1~CH6 in Instrument 1 and CH7~CH12 in Instrument 2, which are intuitive and convenient to display.

- With high-performance components employed in the instrument, its temperature drift is greatly reduced and the interference between six channels is reduced, so that the accuracy and anti-jamming performance of multi-channel measurement are comparable to those of single-channel measurement instruments.
- A maximum of 7 switch outputs or inputs can be supported, which can be used for local alarm or as switch I/O ports controlled by upper computer.
- Built-in calculation functions such as square root, adder, subtracter, maximum value, minimum value and others as well as humidity measurement function with wet and dry bulb.
- There can be at most two mutually isolated transmission current outputs, and the measured values of any channel can be transmitted from the OUTP port for output, which can be programmed to be used as two in two out or one in two type transmitters.
- A variety of panel mounted and DIN rail mounted forms are supported.
- With complete input specifications, Different signal specifications can be used for each input. When the input is linear voltage, current or resistance, each circuit can independently define the scale and decimal point position. When the input is thermocouple or thermal resistance and other temperature sensors, it can independently carry out translation correction and select 0.1/1 °C indicating resolution. Each input circuit has digital filtering, and the filtering intensity can be independently adjusted or canceled.
- Thermocouple measurement can support various high-precision compensation functions such as freezing point compensation, copper resistance compensation and thermostatic bath compensation.
- It has fixed-point/automatic patrol measurement display function, and 2 patrol inspection speeds can be selected.

- Each circuit has independent upper and lower limit alarm functions, and its alarm output position can be specified by programming. The upper or lower limit alarm signals of different input circuits can be programmed to output from the same alarm channel or from different channels. There can be 7 alarm outputs at most.
- As the lower computer, it can provide the computer with switch input/output ports, with a maximum of 7 switch inputs or outputs.
- With 12 field parameter settings, users can "customize" the instrument according to their own usage habits.
- It can support AIBUS and MODBUS communication protocols.

### **Differences between AI-702M, AI-704M and AI-706M**

The number of measurement and display channels of AI-702M, AI-704M and AI-706M can be set as 1~2, 1~4 and 1~6, respectively. When the number of input channels is set to 2, 2 display windows of the instrument will display 2 input signals simultaneously, which is intuitive and convenient. When the number of input channels is set to 1, the lower display window is closed and can be used as a single display. The operation of the three instruments is fully compatible, and AI-706M is downward compatible with all functions of AI-704M and AI-702M.

When the number of measurement channels is more than 4, the AI-704M and AI-706M can be expanded linearly by even numbers, such as 4, 6, 8, 10, 12, 14, 16, etc. The customer will not spend extra money or waste the number of measurement channels.

## 2. Ordering Code Definition

The AI-702M/704M/706M instrument hardware adopts advanced modular design. There are six locations where modules can be installed. M1, M2 and M3 can be installed with various input modules and each module can support 1 to 2 analog inputs; ALM, AUX, M3 (OUTP) can be installed with relay modules for alarm output. Each module can be installed with single or dual relay output modules. M2 (MIO) can also be used as alarm output when necessary, but only single relay output modules can be installed; The COMM is specially used to install the RS485 communication interface module for communication with the upper computer. Among them, M3 (OUTP) and M2 (MIO) are dual-use sockets that can be installed with analog input modules for measuring input and relay modules for alarm output. All inputs and outputs of the instrument can be flexibly programmed.

### 2.1 Selection of Panel Mounted Instrument

<u>AI-706M</u>	<u>A</u>	<u>J1</u>	<u>J2</u>	<u>J51</u>	<u>L3</u>	<u>L3</u>	<u>S</u>
①	②	③	④	⑤	⑥	⑦	⑧

This indicates an instrument: ① the basic function is AI-706M; ② panel size is 96 × 96mm ; ③ two thermocouple input circuits; ④ two two-wire thermistor input circuits; ⑤ there are 2 current input circuits; ⑥ ⑦ 4-way alarm relay output; ⑧ one RS485 communication interface. The meanings of each part in the instrument model are as follows:

**① Indicates the basic functions of the instrument:**

The AI-702M, AI-704M and AI-706M display alarms for 1~2, 1~4 and 1~6 channels respectively

**② It refers to the size specification of the instrument panel. Its depth is about 13.5mm (front)+100mm (rear)**

A panel 96 × 96mm, opening 92 × 92mm

B panel 160 × 80mm (wide × height), horizontal type, opening  $76^{+0.5} \times 152^{+0.5}$ mm

C panel 80 × 160mm (wide × height), vertical, opening  $76^{+0.5} \times 152^{+0.5}$ mm

D71 is only 22.5mm wide, DIN rail installation mode, double row LED display, with key operation, Plug-and-unplug terminals are used for power supply and communication

E Panel 48 × 96mm (wide × high), opening  $45^{+0.5} \times 92^{+0.5}$ mm

The E5 means that the instrument has an I/O modular housing, and there is no display part on the machine. It can be mounted on the DIN rail and programmed with an external display.

F panel 96 × 48mm (width × high), opening  $92^{+0.5} \times 45^{+0.5}$ mm

Note: The size of D71 is a welded module, and the input specification is fixed on the PCB. Please contact customer service for specific input and output support.

**③ ~⑧ respectively represent the modules installed at the positions of M1, M2, M3 (OUT), ALM, AUX and COMM modules of the instrument. The module functions are as follows:**

N: (or do not write) No modules are installed.

J1: two-way thermocouple input module, which can also support mV voltage input.

J2: two-way two-wire thermal resistance input modules.

J3: two-way voltage input modules, which can support input specifications of 0~1V, 0~3V, 0~5V, 1~5V, etc.

J4: two-way current input modules which can support input specifications of 0~12mA, 4~20mA, 0~20mA, etc.

J51: 2-way two-wire transmitter input module, with 24V feed power inside.

I5: 2-way external switch input interface, dry contact, that is, external input is switch signal, which can be used for upper computer to collect switch signal.

L0: Large capacity and large volume relay normally open+normally closed contact switch output module (module capacity: 30VDC/2A, 250VAC/2A, suitable for alarm).

L1: Large capacity and large volume relay normally open contact switch output module (module capacity: 30VDC/2A, 250VAC/2A).

L2: Small capacity small volume relay normally open+normally closed contact switch output module (module capacity: 30VDC/1A, 250VAC/1A, suitable for alarm).

L3: two-way large capacity large volume relay normally open contact switch output module(capacity: 30VDC/2A, 250VAC/2A).

L4: large capacity small volume relay normally open+normally closed contact switch output module(module capacity: 30VDC/2A, 250VAC/2A).

W1: one-way contactless switch output module("unburnable" technology, 0.2A continuous control circuit, instant breaking circuit capacity 2A).

G: one-way solid-state relay drive voltage output module (12VDC/30mA).

G5: 2-way solid-state relay drive voltage output module.

S: Isolate RS485 communication interface module, but it needs to occupy the internal isolation power supply of the instrument.

S1: Photoelectric isolation RS485 communication interface module (use 24V internal power isolation of the instrument).

S4: Isolated RS485 communication interface module with isolated power supply.

X3: Isolate the linear current output module, but it needs to occupy the internal isolation power supply of the instrument.

X5: Linear current output module with isolated power supply.

V24: Isolated 24V/50mA DC voltage output, available for transmitter. Other voltage specifications below 24V can also be customized.

## 2.2 Selection of D71 Rail Mounted Instrument

AI-706MD71   J1   X3   L3   I5   S4 - 24VDC  
①            ②            ③            ④            ⑤            ⑥            ⑦

① **Basic model:** 702M, 704M, 706M.

② **Input:** Only J1 can be selected temporarily.

③ **Main output (OUTP):** X3, X5, L0, L2, L4, L3, I5, G, G5 can be selected.

④ **Alarm (ALM):** L0, L2, L4, L3, I5, G, G5 can be selected.

⑤ **Auxiliary output (AUX):** L2, L4, I5, G, G5 are optional. (Only small volume modules can be selected)

- ⑥ **Communication interface (COMM):** S, S1, S4, S6 are optional.
- ⑦ **Instrument power supply:** 220VAC or 24VDC power supply is optional;

## Further Explanation of Module Functions

The AI-702M/704M/706M instrument has six functional module sockets. Different functions can be realized by installing different types of modules and configuring them.

One two-way input module can be installed respectively for M1, M2 and M3 marked on the instrument circuit board, corresponding to IN1+IN2, IN3+IN4 and IN5+IN6, while input module types include J1 thermocouple (including mV), J2 thermal resistance (two-wire system), J3 voltage (supporting 0~1V, 0~3V, 0~5V and 1~5V inputs), J4 current (supporting 0~10mA and 4~20mA inputs), and J51 two-wire transmitter (4~20mA input in series with 24V DC power supply).

The module positions ALM, AUX and M3 (OUTP) can be installed with output modules for alarm or ON/OFF control. If a one-way output module (such as G, L2, etc.) is installed, only one alarm output (AL1, AU1, and OP1) is supported; if two-way alarm output modules (such as G5, L3, etc.) are installed, each module can support two-way alarm outputs, and the added outputs are AL2, AU2 and OP2 respectively. Please note that the relay with one-way output has normally open + normally closed terminal output, while the relay with two-way output has only a normally open contact, which can be defined as a normally closed contact through the *nonc* parameter. When there is no analog input or alarm, the above modules can also be installed with I5 switch input module to provide the upper computer with switch input function. If it is necessary that M2 (MIO) is not used as input, one-way relay

output module can also be installed as alarm or I5 as switching input. COMM can be installed with S or S4 communication module, which is specially used for communication with computer.

After the module installed and configured according to user's needs, it is necessary to set parameters to correspond to the module. Each channel can support independent upper and lower limit alarm settings, and the alarm signals of each channel can be set to output from the same output terminal or from different output terminals independently. If each channel requires independent output, the AI-704M can be used for 4-way ON/OFF 2-position adjustment or 3-way 3-position adjustment at most.

Modules are usually installed and tested before instrument delivery according to the requirements of users when ordering. Users can also replace the module by themselves (such as when the module is damaged or the function needs to be changed). When replacing the module, pull out the instrument core, carefully pry the joint between the original module and the motherboard socket with a small slotted screwdriver, remove the original module, and then install a new module as indicated.

**Power Isolation of Modules:** For occasions where signals need to be isolated from each other, such as current output and RS485 communication interface, photoelectric isolation technology is used on modules. However, to achieve comprehensive electrical isolation, the power supply between modules and main boards also needs to be isolated. The AI-702M/704M/706M provides a solution that can fully isolate input/output signals and minimize costs. There are one group of 24V and one group of 12V power supplies isolated from the main line inside the instrument for the use of modules, and 24V power supplies are usually used for voltage output modules, such as V24, V12 and V10 modules; 12V power supply can be used for current output and communication module. Relay and thyristor trigger output module usually have their own isolation or do not need to use isolation power supply, while SSR voltage output module (G module) generally does not need additional isolation, because common SSR itself has isolation function. Therefore, it is mainly necessary to consider the isolation between the communication interface and the current output, namely, the input and output terminals of S (RS485 communication interface) and X3 (linear current output) modules are electrically isolated from the instrument input circuit, that is, the main circuit. However, these modules need to use the 12V isolation power supply provided inside the instrument. If the user has installed the above two modules with isolation function at the same time, the two modules cannot be electrically isolated from each other because they share the power supply of the isolation part. For this purpose, new modules such as S4 (RS485 communication interface) and X5 (linear current output) are designed. These modules are equipped with high-efficiency DC/DC power isolation converters, which do not occupy the internal isolated power supply of the instrument. For example, if the X3 module is installed at the OUTP position of the instrument, and the S (or X3) module is installed on the auxiliary function (COMM), the X3 and S (or X3) modules cannot be isolated. Instead, the S4 or X5 module should be installed on the COMM to achieve full signal isolation from each other.

### 3. Technical Specification

- **Input specification:**

Thermocouple: K, S, R, E, J, T, B, N, WRe5-WRe26 (install J1 module)

Linear mV voltage: 0~20mV, 0~60mV, 0~100mV, etc. (install J1 module)

Thermal resistance: Pt100, Cu50, 0~80 ohm, 0~400 ohm, etc. (J2 module is installed, and each module supports two-way inputs)

Linear voltage/current: 0~5V, 1~5V, 0~12mA, 0~20mA, 4~20mA, etc. (install J3 voltage or J4 current input module)

Square root calculation input: 1~5V, 4~20mA, etc. (install J3 voltage or J4 current input module)

Input of two-wire transmitter: directly connect the two-wire transmitter with 4~20mA output, and provide 24V power supply voltage internally (install J51 module)

- **Maximum single lead resistance during thermal resistance wiring:**

2  $\Omega$  for Pt100 and 0~400  $\Omega$  input and 1  $\Omega$  for Cu50 and 0~200  $\Omega$  input in two-wire connection;

- **Measuring range:**

K(-50~+1300 $^{\circ}$ C), S(-50~+1700 $^{\circ}$ C), R(-50~+1700 $^{\circ}$ C), T(-200~+350 $^{\circ}$ C), E(0~+800 $^{\circ}$ C), J(0~+1000 $^{\circ}$ C), B(+200~+1800 $^{\circ}$ C), N(0~+1300 $^{\circ}$ C), WRe3~WRe25(0~+2300 $^{\circ}$ C), WRe5~WRe26 (0~+2300 $^{\circ}$ C), CU50(-50~+150 $^{\circ}$ C), PT100(-200~+800 $^{\circ}$ C)

- **Linear input:** - 1999~+9999 user-defined

- **Measurement accuracy:** level 0.2 ( $\pm 0.2\%$  FS  $\pm 1$  word); level 0.3 ( $\pm 0.3\%$  FS  $\pm 1$  word, only Cu50)

Note 1: When thermocouple input is used and internal cold junction compensation is used, 1 °C should be allowed to compensate the error at the cold junction. When copper resistance, freezing point or thermostatic bath compensation is used, it is not necessary.

Note 2: The B graduation thermocouple can be measured at 60~600 °C, but the accuracy cannot reach the calibration accuracy. The measurement accuracy can be guaranteed at 600~1800 °C.

- **Temperature drift:**  $\leq 0.01\%$  FS/°C (typical value is 50ppm/°C)
- **Electromagnetic compatibility:** IEC61000-4-4 (electric fast transient pulse group),  $\pm 4KV/5KHz$ ; IEC61000-4-5 (surge), 4KV
- **Isolation withstand voltage:** between power supply end, relay contact and signal end  $\geq 2300VDC$ ; between isolated weak current signal terminals  $\geq 600VDC$
- **Response time:**  $\leq 1.5$  seconds (when the digital filtering parameter is set to 0 or 1)
- **Automatic patrol interval:** about 1.2 seconds or 2 seconds can be selected
- **Alarm function:** upper limit alarm and lower limit alarm, each circuit is set independently
- **Alarm output:**
  - Relay contact switch output (software supports normally open or normally closed): 250VAC/1A or 30VDC/1A
  - Contactless switch output (software supports normally open or normally closed): 250VAC/0.2A (instantaneous current 2A)
- **Power supply:** 100~240VAC/50Hz
- **Power consumption:**  $\leq 6W$
- **Operating environment:** temperature - 10~+60 °C, humidity  $\leq 90\%$  RH

- **Panel size:** 96 × 96mm、160 × 80mm、80 × 160mm、48 × 96mm、96 × 48mm,  
D71 rail mounted module optional
- **Opening size:** 92 × 92mm、152 × 76mm、76 × 152mm、45 × 92mm、92 × 45mm

# 4.Wiring

The terminal diagram of instrument back cover is as follows:

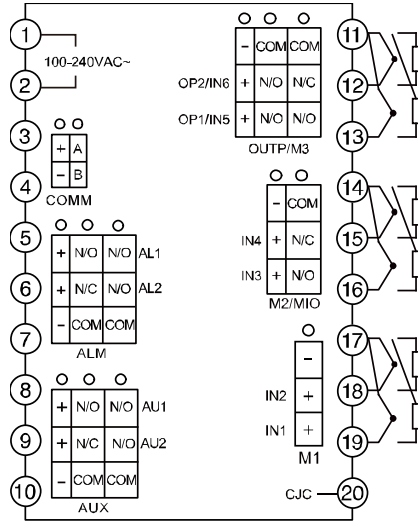

Note: This drawing is the instrument wiring diagram of A/C/E vertical panel

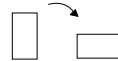

The diagram is the instrument wiring diagram of B/F horizontal panel after 90 degrees clockwise rotation, and the terminal number remains unchanged

The wiring diagram of D71 panel instrument is as follows:

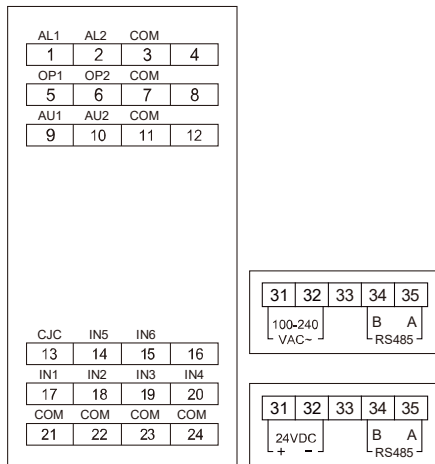

Note: D71 guide rail type shall be subject to its own wiring diagram; In addition, due to technical upgrading or special ordering, if the attached wiring diagram of the instrument is inconsistent with this manual, the attached wiring diagram shall prevail

## **Thermocouple Wiring**

When the thermocouple is connected, the qualified compensation wire shall be directly connected to the terminal of the instrument back cover, and the polarity of the compensation wire shall not be reversed. Wiring yet not according to the above requirements may cause cold junction compensation error. When installing J1 module, M1 can connect Cu50 copper resistor at COM and CJC, and use Cu50 as thermocouple cold end compensation temperature. Short circuit can realize freezing point compensation. COM and CJC correspond to A size terminals 17 and 20.

## **Wiring Mode of Thermal Resistance**

The AI-702M/704M/706M only supports the two-wire thermal resistance connection method. The error resistance value is recorded in the Sc parameter and is offset during measurement.

## **Two-wire Transmitter Input**

AI-702M/704M/AI-706M can provide 24V DC power supply internally, and the maximum output current is 90mA. It can be used for up to four two-wire transmitters. J51 module can be directly connected to two-wire transmitters, which is convenient for wiring. However, it is only recommended to install up to two J51 or V24 power output modules for each instrument. If more transmitters need to be connected, additional 24V current distributor and J4 current input module shall be installed as the connection scheme. If the internal 24V DC power supply of the instrument is used to supply power for more than four two-wire transmitters, it may cause the power load to be too heavy to start, and due to common ground reasons, it may also cause certain measurement errors.

# 5. Display and Operation

## 5.1 Description of Panel Mounted Instrument Panel

- ① Upper display window
- ② Lower display window
- ③ Set key
- ④ Data shift (manual/automatic cycle display and switching)
- ⑤ Data reduction key (switch to display the previous channel)
- ⑥ Data increase key (switch to display the next channel)
- ⑦ 10 LED indicators, of which PRG indicator is not used temporarily; MAN light off indicates automatic cycle display, and on indicates manual cycle display; MIO, OP1, OP2, AL1, AL2, AU1, AU2, etc. correspond to module input and output actions respectively; When the COM light is on, it indicates that the communication with the upper computer is in progress.

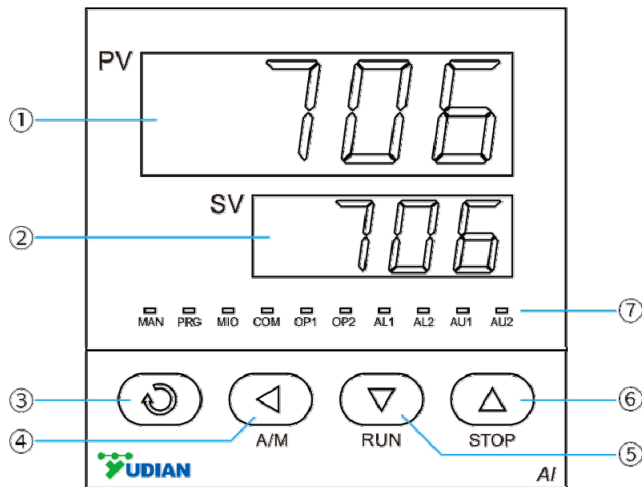

## 5.2 Operating Instructions

1. Switch to display circuit: press (▽) to decrease the circuit number, and press (△) to increase the circuit number. Press (◀) to enter/exit the automatic cycle display state.

2. Setting parameters: When the parameter lock is not locked, press (↻) and hold for about 2 seconds, and release it after the parameter is displayed. Press (↻) again, and the instrument will display each parameter in turn, such as the upper limit alarm value H.AL1 of circuit 1, parameter lock Loc, etc. For the instrument configured and locked with the parameter lock, press (↻) to display the parameters (without holding for 2 seconds), and only the parameters that the operator needs to use (field parameters) will appear. The parameter value can be modified by pressing (▽), (△) and (◀). Press (◀) and then (↻) to exit the parameter setting state, and hold (◀) to return to check the last parameter.

3. The lower display window of the instrument can display the circuit number. When there is an upper limit or lower limit alarm, the first digit on the left of the lower display window can display the flashing H. or L. When the loop signal exceeds the range (such as thermocouple disconnection), the upper display window of the instrument displays the upper or lower range value, and the lower display window flashes.

4. If only 2 input circuits are set for the instrument, the upper and lower display windows will display the measured values of 1 and 2 input circuits respectively. When the input signal exceeds the range, the corresponding display value flashes.

5. Lead wire resistance compensation during two-wire wiring of thermal resistance: if the two-wire wiring mode is used for resistance signals such as Pt100 or Cu50, an offset value (parameter Sc) needs to be set to offset the lead resistance value. The instrument can provide an operation to automatically set the offset value. The steps are as follows:(1) First,

short circuit both ends of the thermal resistance of the channel to be corrected (note that the short circuit point is at the sensor end rather than the instrument end). (2) Set parameter Loc=808, and then press and hold for more than 2 seconds until the symbol A is displayed in the first digit on the right of the lower display of the instrument. (3) When the A displayed by the instrument disappears automatically, remove the short line at the sensor end, set Loc to 0 or 1, and restore the normal measurement state of the instrument. This operation enables the instrument to reverse the measured value and record the Sc parameter of the corresponding channel to compensate the measurement error caused by the lead resistance. If the measurement signal is not of the resistance type, or the line is not shorted, this operation will not work. After operation, check Sc parameter to know the lead resistance, which has been calculated as the value at 0 °C.

### 5.3 Rail Mounted Instrument

If the E5 panel with DIN rail mounting mode is selected, the instrument has no digital display. This instrument can be used as an analog quantity collector and switch input/output port of a computer or PLC, or as a two-way programmable intelligent transmitter. It has the advantage of programmable input specification selection and range setting.

The instrument is equipped with an LED indicator light. When the instrument communicates with the upper computer, it usually flashes with unequal on/off time. Each flash indicates that the instrument communicates with the upper computer once. At this time, the status of the instrument can be viewed through the upper computer. If the instrument does not receive the upper computer signal within 6 seconds, it will flash with the same on/off time, which means:

When the indicator light flashes slowly in a 1.6s cycle, it indicates that there is no communication but the instrument is working without alarm (it can be regarded as normal);

When the indicator flashes rapidly in a 0.6s cycle, it indicates that the instrument has no communication, and there are general errors such as alarm;

When the indicator flashes rapidly in a 0.3s cycle, it indicates that there is no communication and there are serious errors such as input overrange (such as open circuit of thermocouple and thermal resistance);

If the indicator light is off, the instrument is dead or damaged; Normally on (more than 8s) indicates that the instrument is powered on but damaged.

The internal parameters of the instrument can be programmed by connecting a special display with a 1394 socket and a special cable. **Please note that the 1394 socket of this instrument can only be used to connect the display of our company (handheld and rail installation), and cannot be used to connect other 1394 devices.**

**Used as analog quantity collector and switching value input/output port of computer or PLC:** an S or S4 communication module can be installed at the COMM port of the E5 instrument. Through the AIBUS protocol, the upper computer or PLC can set the parameters of the AI-702M/704M/706M, read the measured values of 1~6 channels, control the relay output modules installed at the OOTP, ALM, AUX and MIO positions, or read the switch signals of the switch input modules installed at the above module positions. For the programming method of communication between PLC and instrument, please refer to the AIBUS agreement of PLC and our company, or consult our website or call our free technical support telephone number to get advice from our company.

**Used as a two-way temperature transmitter or signal isolator:** X3 and X5 current output modules should be installed at the OOTP and COMM positions of the AI-702ME5 respectively, in this way, the two-way transmit outputs are isolated from the inputs, and the two-way outputs are also isolated from each other, which can support one in two out and two in two out modes.

## 5.4 On Measuring Humidity with Wet and Dry Bulb Method

The ambient temperature (dry bulb) and humidity can be measured simultaneously by using two-way Pt100 thermistor inputs and the wet and dry bulb method. Under the stable conditions of wind speed and atmospheric pressure, the humidity measurement accuracy after calibration is better than 1% RH. This method is applicable to the measurement range of temperature 0~100 degrees and humidity 0~100% RH, and solves the problem that ordinary ceramic humidity sensors cannot work for a long time under high temperature and humidity. Sn1 is set to 22, Sn2 is set to 42, and atmospheric pressure and wind speed are defined by Po and SPED. Since the small errors of the two Pt100 and the measuring channel will bring large errors to the humidity measurement, it is recommended to calibrate the humidity before measuring the humidity. During calibration, the dry bulb Pt100 can also be wrapped with gauze under the same conditions as the wet bulb. After stabilization, please adjust the Sc2 parameter to make the humidity display value 100%, and then remove the dry bulb gauze. In this mode, the temperature measurement resolution is 0.01 ° C, and the humidity measurement resolution is 0.1% RH, but the last digit is unstable. It is recommended to set DIP1=1, DIP2=0, so that the display resolution is 0.1 °C and 1% RH respectively.

## 6 .Parameters

AI-702M/704M/706M defines the input, output, alarm and communication modes of the instrument through parameters, as shown below:

<b>Parm.</b>	<b>Meaning</b>	<b>Description</b>	<b>Range</b>
H.AL1~6	Alarm value of upper limit absolute value	<p>They respectively represent the upper limit alarm values of 1-6 measurement channels. When the measured value of the corresponding channel is greater than H.ALx (x is 1~6, indicating the corresponding measuring channel, the same below), the upper limit alarm will be generated. After it is generated, the alarm will be released when the measured value of the corresponding channel is less than H.ALx-dFx.</p> <p>However, the AI-702M and AI-704M have only 1~2 and 1~4 channel alarm value parameters respectively. The following parameters are the same.</p>	-1999~ +9999 linear units or 1 °C

L.AL1~6	Alarm value of lower limit absolute value	<p>They respectively represent the lower limit alarm values of 1~6 measurement channels. When the measured value of the corresponding channel is less than L.ALx, the lower limit alarm will be generated. After it is generated, it will be released when the measured value of the corresponding channel is greater than L.ALx+dFx. Alarms can control the action of relay modules on ALM, AUX or OUTF, and are programmed by parameters ALP1~6.</p> <p>The unused alarm function can be set as the limit value to avoid its alarm effect.</p>	ditto
dF1~6	Backlash (dead time, hysteresis)	<p>In order to avoid frequent on-off maloperation caused by alarm or position adjustment due to the fluctuation of measured input value, the instrument is set with a backlash parameter dF (also called insensitive zone, dead zone, hysteresis, etc.)</p>	0~999.9 °C or 0~9999 linear units

Sn1~6	Input specifications	Sn1~6 defines the input specifications of 1~6 channels respectively.				0~39
		Sn	Input specification	Sn	Input specification	
		0	K	1	S	
		2	R	3	T	
		4	E	5	J	
		6	B	7	N	
		8	WRe3-WRe25	9	WRe5-WRe26	
		10	User specified extended input specifications	12	F2 High temperature radiation thermometer	
		19	Ni120	20	Cu50	
		21	Pt100	22	Pt100 (-100.00~+300.00°C)	
		23.24	Stand-by	25	0~75mV	
		26	0~80 ohm resistance input	27	0~400 Ω resistance input	
		28	0~20mV voltage input	29	0~100mV(J1); 0-5V(J3); 0-20mA(J4)	
		30	0~60mV voltage input	31	Stand-by	
		32	20~100mV(J1); two-wire transmitter (J51)	33	1~5V(J3); 4-20mA(J4)	
38	The same as the square root input of 32	39	The same as the square root input of 33			

		<p>Note: The input specification setting should correspond to the input module, J1 for thermocouple and mV input, and J2 for two-wire resistance. When Sn3-5=41, channels 3-5 are the sum of the measured values of the previous channels, which can be used as an adder; When Sn3=42, PV3=PV2-PV1, namely the subtracter function; When Sn2 is set to 42, and Sn1 is set to 22, the humidity is measured by wet and dry bulb method.</p>	
--	--	---	--

dIP1~6	Decimal point position	<p>DIP1~6 are respectively used to select the decimal point position and resolution of 1~6 channels.</p> <p>(1) For linear input, dIP=0, 1, 2, 3 corresponds to 0, 0.0, 0.00 and 0.000 display modes.</p> <p>(2) When thermocouple or thermal resistance input is used, dIP selects the temperature display resolution, sets dIP=0, and the temperature display resolution is 1 °C. DIP=1, temperature display resolution is 0.1 °C.</p> <p>Note: This setting is only valid for display. The internal temperature measurement resolution is fixed to 0.1 °C or 1 linear definition unit, so it does not affect the communication or transmission output effect. When the temperature display resolution is set to 0.1 °C, and the temperature measurement value is above 1000 °C, it will automatically change to 1 °C resolution.</p>	0~3
dIL1~6	Lower limit of input signal scale	<p>For linear input: the linear input of the instrument includes mV, 0~5V, 1~5V, 0~10mA, 4~20mA and other signals of various specifications. The maximum value display range of the signal is -999~+9999, and the decimal point is defined by dIP. The parameters dIL and dIH are used to define the linear input display range, which can be used to set the unit of the measured physical quantity. When used as a temperature transmitter, dIL is also used to define the lower limit of the transmitting output range of the corresponding channel.</p>	-9990~ +30000 linear units or 0.1 °C

dIH1~6	Upper limit of input signal scale	<p>DIH is used to define the upper scale limit of the input signal; When used as a temperature transmitter, dIH is also used to define the upper limit of the transmitting output range of the corresponding channel.</p> <p>For example, the pressure (temperature, flow, humidity and other physical quantities) is converted into standard 1~5V signal input by pressure transmitter. If the 1V signal pressure is 0 and the 5V signal pressure is 1MPa, it is expected that the instrument display resolution is 0.001 MPa. Taking loop 1 as an example, the parameters are set as follows:  Sn1 = 33 ; dIP1=3; dIL1 = 0.000 ; dIH1 = 1.000</p>	-9990~ + 30000 linear units or 0.1 °C
--------	-----------------------------------	---	--

Sc1~6	Input translation correction	<p>Sc parameter is usually used for translation correction of thermocouple to compensate the error of sensor or input signal itself, or to correct the compensation error of instrument cold end; When a two-wire thermistor input is used, Sc is used to correct the lead error of the two-wire thermistor.</p> <p>When the input is thermocouple, the unit of Sc correction is 0.1 °C. For example, if Sc=- 10.0 is set, the measured value will decrease by 10.0 °C compared with Sc=0.0.</p> <p>When the input is a two-wire resistance signal:</p> <p>Sn=19 SC=6.25 corresponds to 1 ohm.  Sn=20 SC=25.0 corresponds to 1 ohm.  Sn=21 SC=6.25 corresponds to 1 ohm.  Sn=22 SC=1.25 corresponds to 1 ohm.</p> <p>Taking Sn=21 as an example, suppose that 20 °C (107.794 Ω) needs to be corrected to 25 °C (109.735 Ω), and Sc needs to be set to <math>(109.735 - 107.794) * 6.25 \approx 12.1</math>. Make correction near room temperature, Sc is about 2.4 times of the temperature to be corrected.</p> <p>During the annual metrological verification of the instrument, if the error of the instrument used for a period of time in harsh environments exceeds the range, the instrument can be cleaned and dried first, which can generally solve the problem. If the accuracy still cannot be reached, the Sc parameter can be modified.</p>	-1999~ +9990 definition unit or 0.1 °C
-------	------------------------------	---	--

dL1~6	Digital filter strength	DL is used to set the strength of digital filtering. 0 does not have any filtering, 1 only takes median filtering, and 2~40 both take median filtering and integral filtering. The greater the dL, the more stable the measured value, but the slower the response. Generally, when the measurement is greatly disturbed, the dL value can be increased gradually to make the instantaneous runout of the measured value less than 2~5 words. When the instrument is calibrated in the laboratory, dL should be set to 0 or 1 to improve the response speed.	0~40
-------	-------------------------	--	------

ALP1~6	Alarm Output Position Definition Parameters	<p>ALP is used to define the output position of H.AL and L.AL alarm functions. The single digit of parameter ALP indicates the output position of H.AL alarm. The value range is 0~7. 0 indicates that the alarm is not output from any port. 1, 2, 3, 4, 5, 6 and 7 respectively indicate that the alarm is output by OP1, OP2, AL1, AL2, AU1, AU2 and MIO. OP2, AL2 and AU2 can only be used when two-way relay output modules such as L3 are installed on the corresponding module position. The ten digits of this parameter represent the output position of L.AL alarm, and the numerical meaning is the same as above. For example, if ALP1=43 is set, it means that H.AL alarm of loop 1 is output by AL1, and L.AL is output by AL2. For another example: ALP2=53, it means that H.AL of loop 2 is output by AL1, and L.AL is output by AU1.</p> <p>In addition to the alarm output, various relay modules installed in the instrument's MIO, OUTP, ALM and AUX can also be commanded by the upper computer through the RS485 interface to make it act. What's more, the switching value input module (I5) can also be installed to collect the switching value data for the upper computer. Please refer to its communication protocol for details. If the upper computer wants to fully control its action, do not set the corresponding port (such as 0) when setting the ALP parameter, then the alarm will not cause its action, the upper computer can obtain the control right of the port, and the upper computer can control the relay of the corresponding position to turn on or off by writing the nonc parameter.</p>	0~77
--------	---	---	------

Cn	Number of measurement routes	The single digit of parameter Cn indicates the actual number of measurement paths used by the instrument. The AI-706M can be set to 1~6, the AI-704M can be set to 1~4, and the AI-702M can be set to 1~2. When Cn is set to 2, the lower display window of the instrument does not display the channel number, but displays the measured value of loop 2. At this time, the instrument is equal to a two-way display instrument.	1~6
Cno	Channel display start number	Cno is used for the lower display window to indicate the starting number of the channel sign. When more than two patrol meters are used, the starting channel number can be modified. For example, when the first instrument displays CH1~CH6, if the Cno parameter of the second instrument is set to 7, the second instrument can display CH7~CH12 to facilitate differentiation. However, AI-702M does not have this parameter.	

AF	Advanced Function Selection	<p>AF advanced function selection is used to select multiple functions, and its numerical meanings are as follows:</p> $AF=A*1+B*2+C*4+D*8+E*16+F*32+G*64+H*128$ <p>A=0, normal speed cycle display; A=1 fast cycle display.  B=0, standby function.  C=0, standby function.  D=0, normal use; D=1, change the lower limit alarm of each instrument circuit to the upper limit alarm.  E=0, standby function.  F=0, standby function.  G=0, 2 channels of measured values are transmitted for each communication; G=1, one channel of measured value is transmitted each time.  H=0, the instrument communication protocol is AIBUS; H=1, the instrument communication protocol is standard MODBUS.</p>	
----	-----------------------------	---	--

nonc		<p>One-way alarm relay can have normally open+normally closed output at the same time, while two-way alarm module L3 only has normally open output, and normally open output can be defined as normally closed output through the nonc parameter. When nonc=0 is set, L3 relays installed at MIO, OP1, OP2, AL1, AL2, AU1 and AU2 are normally open outputs. When nonc=127 is set, instrument alarms are normally closed outputs. When it is required that some channels are normally open and some channels are normally closed, the nonc value can be calculated according to the following formula.</p> $\text{Nonc} = A * 1 + B * 2 + C * 4 + D * 8 + E * 16 + F * 32 + G * 64$ <p>In the formula, A, B, C, D, E, F and G represent the normally open and normally closed selection of OP1, OP2, AL1, AL2, AU1, AU2 and MIO respectively. When the value is 1, the corresponding alarm is normally closed output, and when the value is 0, the corresponding alarm is normally open output.</p>	0~127
------	--	---	-------

OPn	Transmitting output channel number	<p>OPn=0, OOTP position is used for alarm output.</p> <p>OPn=1~4, respectively representing the measured values of 1~4 channels transmitted by OOTP.</p> <p>OPn=7, indicating the minimum value of each effective measurement channel (determined by Cn) transmitted by OOTP.</p> <p>Opn=8, indicating the maximum value of each effective measurement channel (determined by Cn) transmitted by OOTP.</p>	0~8
OPL	Lower limit of transmitting output current	When the OOTP module of the instrument is used to measure the transmitting output of the channel, OPL is used to define the lower limit of the transmitting output current, and the unit is 0.1mA.	0~110
OPH	Upper limit of transmitting output current	When the OOTP module position of the instrument is used to measure the transmit output of the channel, OPH is used to define the upper limit of the current, and the unit is 0.1mA. For example, if the measured value of channel 1 needs to be transmitted and output at 0~600 °C to 4~20mA, the parameters are set as follows: dIL1=0, dIH1=600, OPn=1, OPL=40, OPH=200	0~220
Po	atmospheric pressure	When measuring humidity with the dry and wet bulb method, define the atmospheric pressure so that the humidity can be calculated correctly, and the unit is KPa	1~120.0



SPEd	wind speed	When measuring humidity with the dry and humidity bulb method, define the wind speed in m/S (m/s).	0.01~10.00
Addr	Communication address	It is used to define the communication address of the instrument, whose valid range is 0~80. Instruments on the same communication line shall be set with different Addr values to distinguish each other. When the communication protocol adopts AIBUS, the AI-706M can measure 1~6 loops, and the corresponding AI-706M needs to occupy 1~6 addresses, which is equivalent to 1~6 single-loop instruments on the communication line. For example, if the number of measuring loops (the single digit of parameter Cn) is set to 6, Addr=1, then the addresses from 1 to 6 are used by the instrument, and other instruments cannot use addresses from 1 to 6. If the number of measuring loops is set to 3 and Addr=10, then 10~12 addresses are used by the instrument. MODBUS takes only one address.	0~80

bAud	Baud rate	<p>When the COMM module interface of the instrument is used for communication, the bAud parameter defines the communication baud rate, and the definable range is 0~19200bit/s (19.2K).</p> <p>When the setting range of bAud is between 0 and 220, the COMM module can be used for channel 2 measurement value transformation output (X3 or X5 linear current output module should be installed). Addr and baud can define the linear current size of the corresponding measurement value transformation output, where Addr represents the lower limit of output, and bAud represents the upper limit of output. The unit is 0.1 mA. For example, the function of 4~20mA transmitting output current is defined as: Addr=40, bAud=200.</p>	0~ 19.2K BIT/S
Loc	Parameter modification level	<p>Loc=0, it is allowed to display and modify field parameters (field parameters can be defined by customers with EP1~EP12).</p> <p>Loc=1, only field parameters can be displayed, but cannot be modified.</p> <p>Loc=808, all parameters can be displayed and set.</p>	0~9999

EP1~12	Field parameter definition	<p>After the instrument is set, the parameters that do not need to be changed frequently can be shielded, leaving only the parameters that need to be changed frequently for the field operators to modify. EP1~EP12 parameters are used to define which parameters can be displayed (i.e. field parameters) when the parameter lock is locked, while the other parameters are shielded and cannot be displayed or modified. EP1~EP12 can define 0~12 field parameters for field operators. The parameter values are other parameters besides EP parameters, such as H.AL1, L.AL1, etc. When Loc is locked, only the defined parameters or program settings can be displayed, and other parameters cannot be displayed or modified. This function can speed up the modification of parameters, and prevent important parameters (such as Sn1~6) from being modified by mistake. If the field parameters are less than 12 (sometimes even none), the first parameter not used is defined as nonE. For example, an instrument site often needs to modify the upper limit alarm H.AL1 parameter of each channel, and the EP parameter can be set as follows:</p> <p>EP1=H.AL1, EP2=H.AL2, EP3=H.AL3, EP4=H.AL4, EP5=H.AL5, EP6=H.AL6, EP7=nonE</p> <p>When Loc=0 is set again, the instrument can only display and modify H.AL1~H AL6 and other 6 parameters. In some cases, field parameters are not required after instrument commissioning, and EP1 parameters can be directly set to nonE.</p>	NonE ~ BAud
--------	----------------------------	---	----------------

## 7. FAQs

### 7.1 How to enter the parameter list?

Press and hold  for two seconds to enter the parameter list, and then press  briefly to find the next parameter. If the parameters are locked, first find the password lock parameter LOC and set 808, then press  briefly to see all the parameters.

### 7.2 Common faults

When the value displayed in the instrument window flashes, it indicates that there is no input signal of the instrument, which may be that the input signal is not connected or the input signal exceeds the range. When the symbol H or L flashes in the SV window, it indicates that the corresponding input channel has an upper or lower limit alarm.

### 7.3 How to set alarm parameters?

First, set the alarm parameters to the desired values (for example, if you need to set the 200 degree upper limit alarm of the first channel, change the H.AL1 parameter to 200), and then enter the internal parameters to find the alarm signal output port defined by the ALP parameter (for example, if you need to output the upper limit alarm of the first channel from AL1, set the ALP1 bits to 3. For specific definitions, see the ALP parameter introduction in the manual).